



Each meter has been calibrated on mineral oil and will contain a small amount of oil residue.

The oil used is Castrol Diesel Calibration Fluid 4113 (product code 055830).



OVAL GEAR

Small capacity positive displacement flowmeter

INSTRUCTION MANUAL

Models : OM004, OM006, OM008

Flomec Factory.

1 / 19 Northumberland Road,
Caringbah NSW 2229, Sydney
AUSTRALIA

tel : +61 2 9540 4433

fax : +61 2 9525 9411

email : sales@flomec.com.au

website : www.flomec.com.au

USA

916 Belcher Drive
Pelham, AL 35124
USA

Tel : +1 205 378 1050

Fax : +1 205 685 3001

Email : customerservice@trimecus.com

Website : www.trimecus.com

Distributed by:



1.0 General		Page
1.1	Overview	2
1.2	Operating principal	2
1.3	Model coding	3
1.4	Specifications	4
2.0 Installation		5
2.1	Mechanical installation	5
2.1.1	Orientation	5
2.1.2	Flow conditioning & locations	6
2.2	Electrical installation	7
2.2.1	Instrument cable	7
2.2.2	Hazardous area wiring	7
2.3	Pulse output selection	7
2.3.1	Hall sensor pulse output	7
2.3.2	Reed switch pulse output	8
2.3.3	DIN plug wiring connections	8
2.4	Meter calibration factor (<i>K-factor or scale factor</i>)	8
3.0 Commissioning		9
4.0 Maintenance		10
4.1	Disassembly of pulse meter	10
4.2	Spare parts	11
4.3	Inspection & exploded view	12
4.4	Re-assembly of meter	12
5.0 Fault Finding		13
5.1	Trouble shooting	14

General

1.1 Overview

The Oval Gear meter is a precise positive displacement flowmeter incorporating a pair of oval geared rotors. These meters are capable of measuring the flow of a broad range of clean liquids.

Stainless Steel flowmeters are suited to most water based products and chemicals and aluminum meters are suitable for fuels, fuel oils & lubricating liquids.

The flowmeter is available as a blind meter with pulse output capable of interfacing to most monitoring and control instrumentation or the meter can be fitted with or supplied with instruments such as totalisers, rate totalisers or batch controllers. These instruments also have monitoring and control output options including 4-20mA, scaled pulse, flowrate alarms and batch control logic (*preset metering*).

If your flowmeter is fitted or supplied with an instrument please also refer to the relevant instrument instruction manual.

These flowmeters can be installed within hazardous areas by using the reed switch pulse output in Intrinsically Safe loops or fitting Intrinsically Safe certified Instruments. Please consult the factory for the availability of flameproof models.

1.2 Operating Principle

The Oval Gear meters are positive displacement flowmeters where the passage of liquid causes two oval geared rotors to rotate within a precision measuring chamber and with each rotation a fixed volume of liquid is displaced passing through the meter. Magnets embedded within the rotors initiate a high resolution pulse train output. The pulse output can be wired directly to process control and monitoring equipment or can be used as an input to instruments supplied with or fitted directly to the meter.

The benefits of this technology allow precise flow measurement and dispensing of most clean liquids irrespective of their conductivity, with other liquid characteristics having nil or minimal effect on meter performance. This metering technology does not require flow profile conditioning as required with alternative flow technologies making the installation relatively compact and low cost.

OPERATION :

Liquid travels around the crescent shaped chambers created by the rotational movement of the rotors

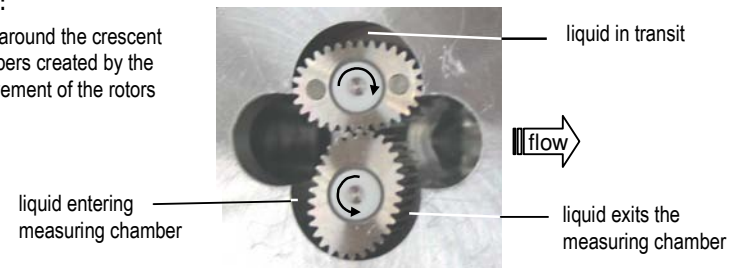

1.3 Model coding

OM004	4mm (1/8")
OM006	6mm (1/4")
OM008	8mm (3/8")

Body material

A	Aluminum
S	316 Stainless Steel
H	High Pressure 316SS

Rotor material

5	316 stainless steel
----------	---------------------

Bearing type

1	Ceramic
----------	---------

O-ring material

1	Viton (standard) -15~+200°C (-5~+400°F)
2	Ethylene Propylene Rubber -150°C (300°F) max.
3	Teflon encapsulated viton -150°C (300°F) max.
4	Buna-N (Nitrile) -65~+100°C (-53~+212°F)

Temperature limits

- 2	120°C (250°F) - see note 1
- 5	120°C (250°F) - see note 2

Process connections

1	BSP female threaded
2	NPT female threaded

Cable entries

<i>with DIN plug & BT11 only</i>	0	3~6mm cable gland
	1	M20 x 1.5mm
	2	1/2" NPT

Model No. Example

OM006 S 5 1 1 - 5 1 2 R2

Integral options

2 NPN open collector phased outputs	QP	Quadrature pulse output
IECEX & ATEX approved	E1	Explosion proof ~ Exd
IECEX & ATEX approved	Q1	Exd with Quadrature pulse
accum. & reset totals, pulse output	B2	BT11 dual totaliser
IECEX & ATEX approved	B3	Intrinsically safe BT11 (I.S.)
flow rate, totals & all outputs	R2	RT12 Flow Rate Totaliser
IECEX & ATEX approved	R3	Intrinsically safe RT12 (I.S.)
dc 2 stage batch controller	E0	EB10 batch controller
consult factory	SB	Specific build requirement

(1) 120°C (250°F) rating of the pulse meter, 80°C (180°F) rating with BT, RT & EB options.
See temperature code 5 for higher temperature with BT, RT, & EB

(2) Cooling fin is fitted with integral instruments for operation from 80~120°C (180~250°F)

1.4 Specifications

Model prefix :	OM 004	OM 006	OM 008
Nominal size (inches)	4mm (1/8")	6mm (1/4")	8mm (3/8")
Flow range - litres / hr (US gal./hr)	0.5 ~ 36 (0.13 ~ 9.5)	2 ~ 100 (0.5 ~ 27)	15 ~ 550 (4 ~ 145)
Accuracy @ 3cp	±1% o.r. (±0.2% with optional RT12 using NLC)		
Repeatability	typically ±0.03%		
Temperature range	-20°C ~ +120°C (-4°F ~ +250°F)		
Maximum pressure			
aluminium	15 bar (220 psig)		
316L stainless	34 bar (500 psig)		
high pressure stainless	refer factory		
Protection class	IP66/67 (NEMA4X), optional Exd IIB T6 or I.S.		
Recommended filtering	75 micron (200 mesh) minimum		
Electrical - for pulse meters (see also optional outputs)			
Output pulse resolution	pulses / litre (pulses / US gallon) - nominal		
Reed switch	2890 (10940)	2100 (7950)	355 (1345)
Hall effect	2890 (10940)	2100 (7950)	710 (2690)
** Reed switch output	30Vdc x 200mA max.		
Hall effect output (NPN)	3 wire open collector, 5~24Vdc max., 20mA max.		
Optional functions			
Display	flowrate, total (accumulative & resettable)		
Preset batching	1 & 2 stage high speed batch control		
Optional outputs			
Flow	4 ~ 20mA, high & low flow rate alarms		
Pulse	scaled pulse (programmable), pulse amplifier		

* Max. flow is to be reduced as viscosity increases, max. press. drop 100Kpa. (15 psi)

** Maximum thermal shock 10°C (50°F) / min. applies to the reed switch

2.0 Installation

2.1 Mechanical Installation *Prior to installing the meter check :*

The fluid is compatible with the meter materials of construction using appropriate information such as fluid compatibility charts and site experience.

Application and process conditions are compatible with the meter specifications. Minimum and max. flows are within the meter specified range including any in-situ cleaning processes. When metering viscous liquids the maximum allowable flow may need to be reduced to ensure the pressure drop across the meter does not exceed 100 kPa (1 Barg, 15 PSIG).

Process temperature and pressure does not exceed meter ratings.

The meter is not exposed to process temperatures and pressures that will cause the liquid medium to gasify (flash) within the meter.

2.1.1 Orientation

The flowmeter MUST be mounted so that the rotor shafts are in a horizontal plane. This is achieved by mounting the meter so that the terminal cover or integral instrument display, whichever is fitted, is facing in a horizontal direction. Note the terminal cover or instrument display can be rotated in 90 degree increments to provide access to the electrical entry and to allow the display orientation to suit the installation.

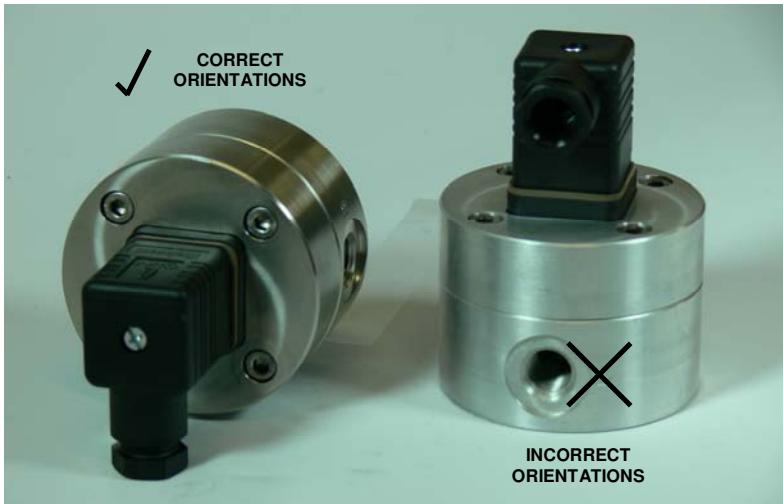

The meter will operate in the alternative orientation, however, it is likely its life & performance will be reduced as a result of the gravity pull on the rotors.

Liquid can flow into the meter from either a horizontal or vertical direction. For vertical flow installations the most common orientation is for the liquid to rise through the meter (*i.e. travel from bottom to top*) to assist in air or entrained gas elimination. The meter operation is independent of the liquid flow direction thus there is no markings for inlet or outlet.

2.1.2 Flow Conditioning and Locations

Strainer: It is recommended to INSTALL a 200mesh (75 micron) strainer immediately upstream of (prior to) the meter. Strainers are available from the factory.

Flow conditioning: The flowmeter does not require any flow conditioning, therefore straight pipe runs before or after the meter are not required. If required, the pipe size about the meter can be altered to suit the installation.

Locations: The flowmeter is preferred to be fitted upstream of any flow control and/or shut off valve, this prevents free discharge from the meter and minimizes the risk of drainage and air entrapment which can result in erroneous readings or damage the meter on start up.

Process or safety critical meters should be installed in a by-pass section of pipe with isolation valves to enable the meter to be isolated and serviced as required. A by-pass installation also allows purging of the system during commissioning (*see Commissioning*). The meter must be appropriately rated and is typically located downstream (*on the discharge side*) of the pump.

If mounted outdoors ensure a suitable watertight gland or plug is used to seal any open electrical entries. In humid environments take precautions to avoid condensation build up within the electrical and/or instrument enclosure. It is good wiring practice for conduits to be connected from the bottom of an entry port, in this way condensation will gravitate away from any terminal housing.

Fluid state: Fluid entering the meter must remain a liquid at all times so protect the meter to avoid solidification or gelling of the metered medium. If meters are to be trace heated or jacketed in any way the maximum temperature rating of the meter must not be exceeded. Size the meter to avoid gasification of volatiles (*flashing*) within the liquid due to the pressure drop experienced within the system or within the meter.

Hydraulic shock: If pressure surges or hydraulic shock of any kind is possible, the system upstream of the meter must be fitted with a surge suppressor or pressure relief valve to protect the meter from damage. High frequency flow pulsations can damage the meter. Such pulsations can be caused by the injection profile in diesel engines. Most pulsations are removed with the installation of a suitable pulsation dampener.

2.2 Electrical Installation

2.2.1 Instrument Cable Twisted pair low capacitance shielded instrument cable 7 x 0.3mm (0.5mm2) should be used for electrical connection between the flowmeter and remote instrumentation. The cable should be between 3-6mm outside diameter and the screen should be earthed at the readout instrument only to protect the transmitted signal from mutual inductive interference.

The cable should not be run in a common conduit or parallel with power and high inductive load carrying cables as power surges may induce erroneous noise transients onto the transmitted pulse signal or cause damage to the electronics. Run the cable in separate conduit or with other low energy instrument cables. The maximum transmission distance is typically 1000m (3300 Ft).

2.2.2 Hazardous area wiring Intrinsically safe wiring including using the reed switch pulse output as simple apparatus, wiring to an Intrinsically Safe Instrument wiring techniques must be undertaken in accordance with the rules, regulations and requirements applying to the territory in which the meter is being installed. The meters should only be connected by qualified staff, the qualified staff must have knowledge of protection classes, regulations & provisions for the apparatus in hazardous areas.

If the flowmeter is supplied with an intrinsically safe instrument refer to the appropriate manual & I.S. supplement for wiring of the instrument inputs and outputs.

2.3 Pulse Output selection Two types of output are available on each meter, open collector from Hall Effect sensors or reed switch contact. Each output type is linearly proportional to volumetric flow and each pulse is representative of an equal volume of liquid.

2.3.1 Hall Effect Sensor Pulse Output The Hall Effect Sensor is a solid state 3 wire device providing a NPN open collector output. It requires a dc voltage between 5-24Vdc to operate and is the recommended pulse output for powered installations such as local or remote batching.

The pulse output between signal \square and -0V is a voltage square wave with the high level being the dc voltage available at the open collector \square and the low level being -0V.

The receiving instrument must incorporate a pull up resistor (typically greater than 10K ohms in most instruments) which ties the open collector to the available dc voltage level when the Hall sensor is not energized. When energized the open collector output \square is pulled to ground through the emitter (-0V).

2.3.2 Reed Switch Pulse Output The reed switch output is a two wire normally open SPST voltage free contact ideal for installations without power or for use in hazardous area locations when Intrinsically Safe (I.S.) philosophy is adopted. **Note:** when using the reed switch output the liquid temperature must not change at a rate greater than 10°C per minute (50°F per minute). In general the reed switch life will exceed 2 billion actuations when switching less than 5Vdc @10mA as is the case when combined with the Flomec RT, EB or BT instruments.

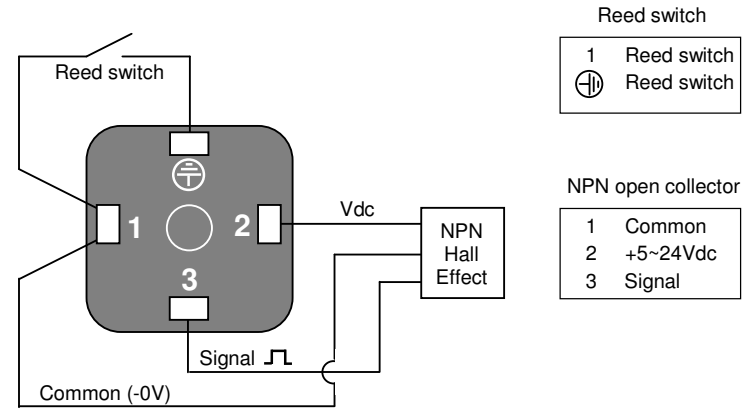

2.3.3 DIN plug connections The DIN plug will accommodate a 3-6mm outside diameter multi core cable. To dismantle the plug first completely remove the centre retaining screw, once fully clear of its mating thread the screw may be pulled free of the plug housing enabling the inner plug to be prised out (see lift arrow marking on underside of the inner plug).

The plug solder tabs must be removed for crimping and soldering the appropriate connections. Both the reed switch & open connector may be used concurrently without damage to either device. On re-assembly the outer case of the plug may be positioned at any of the 4 positions to suit installation.

2.4 Meter Calibration Factor (K-factor or scale factor) Each flowmeter is individually calibrated and supplied with a calibration certificate showing the number of pulses per unit volume (eg pulses per litre or pulses per USgallon). Nominal figures are shown in the specification section of this manual.

3.0 Commissioning Once the meter has been mechanically and electrically installed in accordance with this and any other relevant instrument manual(s) the meter is ready for commissioning.

The meter must NOT be run until the pipework is flushed of foreign matter, more often than not foreign matter is present after pipework fabrication or modification, weld slag, grinding dust, sealing tape & compound &/or surface rust are most common offenders.

Flushing can be undertaken by utilizing a by-pass or removing the meter from the pipework. If neither is practical then the meter rotors must be removed prior to flushing (*refer to Maintenance section of this manual for disassembly*).

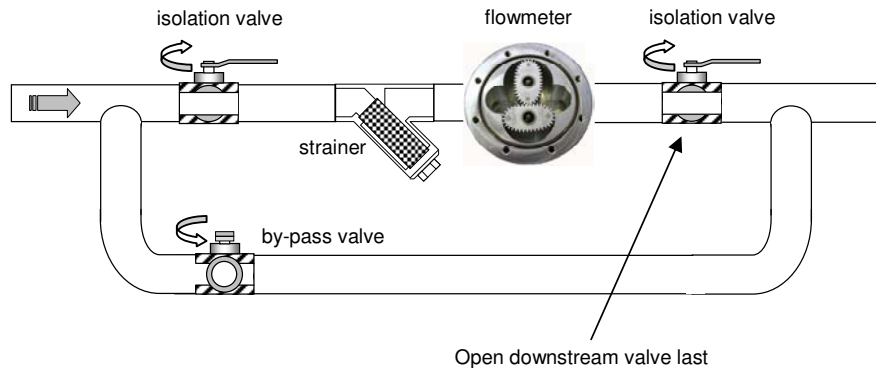

After flushing or following long periods of shutdown the meter must be purged of air/vapour. This can be achieved by allowing the liquid to flow through the meter at a slow rate until all air/vapour is displaced. Never run the meter above its maximum flow or exceed 100kpa (1 bar, 15psi) pressure drop across the meter. Now the meter is ready for its operation to be confirmed by ensuring correct indication or operation at the receiving instrument(s). Refer if necessary to fault finding section of this manual.

4.0 Maintenance Adhering to the installation instructions in this manual should ensure your meter provides the required operational performance. These are mechanical meters and a periodic maintenance and inspection regime will maximize the operational availability of the meter.

The frequency of maintenance depends on the application factors including liquid lubricity and abrasiveness and operational factors such as flowrate and temperature.

BEFORE undertaking meter maintenance ensure the following :

Associated alarm(s) or control output(s) are isolated so not to affect the process.

Voltage supply is isolated from the meter.

Liquid supply to the meter is closed off.

The meter is depressurized and liquid drained from the meter.

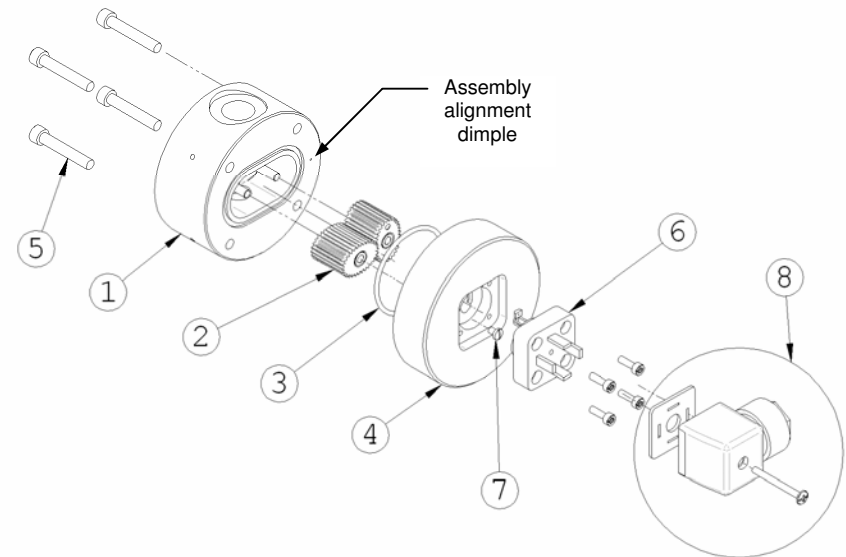

4.1 Disassembly of meter (Refer Exploded View) If required to gain access to the pulse output board, undo the DIN plug screw, remove the plug, 4 screws holding the DIN plug base in place & the PC board retaining screw, the PC board can now be removed.

If required to gain access to the oval geared rotors undo the 4 body screws (3), carefully pry the meter body apart avoiding misplacing or damaging the O-ring (4) and rotors (2). Note items 1 & 5 are marked with a dimple and both dimples must align when reassembling, in addition (*models OM004 & OM006 only*) the rotor shaft located closest to the dimple must take the driving rotor which is the rotor fitted with magnet(s).

4.2 SPARE PARTS (refer to exploded view)

Item Description	OM004	OM006	OM008
1 Body / shaft assembly	Part No.		
aluminum - BSP	1402082	1402050	1402054
aluminum - NPT	1402083	1402051	1402055
stainless steel - BSP	1402080	1402052	1402056
stainless steel - NPT	1402081	1402053	1402057
2 Rotor assembly set			
stainless & aluminum meters	1524010	1524006	1524007
3 Body O-ring	(size BS022)	(size BS024)	(size BS030)
viton (standard)	13030221	13030241	13030301
EPR	13030222	13030242	13030302
teflon	13030223	13030243	13030303
buna-N	13030224	13030244	13030304
4 Meter cap			
aluminum	1302179	1302090	1302090
stainless steel	1302178	1302091	1302091
5 Body screw			
stainless & alum. meters (M5 x 30)	130805120	130805120	130805120
6 Pulse output board assembly			
standard pulse board	1412054	1412052	1412053
7 Output board screw			
stainless steel	130803101	130803101	130803101
8 DIN cable socket			
Hirschmann GDMC 3016	13030321	13030321	13030321

Recommended spare parts :

Item 2 rotor / bearing set
Item 3 body O-ring
Item 6 pulse output board

4.3 Inspection (refer Exploded View) Inspect O-rings for damage, chemical attack, deformity or any form of deterioration.

Remove, inspect and clean the rotors, also check that the magnets have not been chemically attacked. Check the measuring chamber for damage or scoring & redress if necessary, the rotor shafts should NOT be loose or able to be rotated.

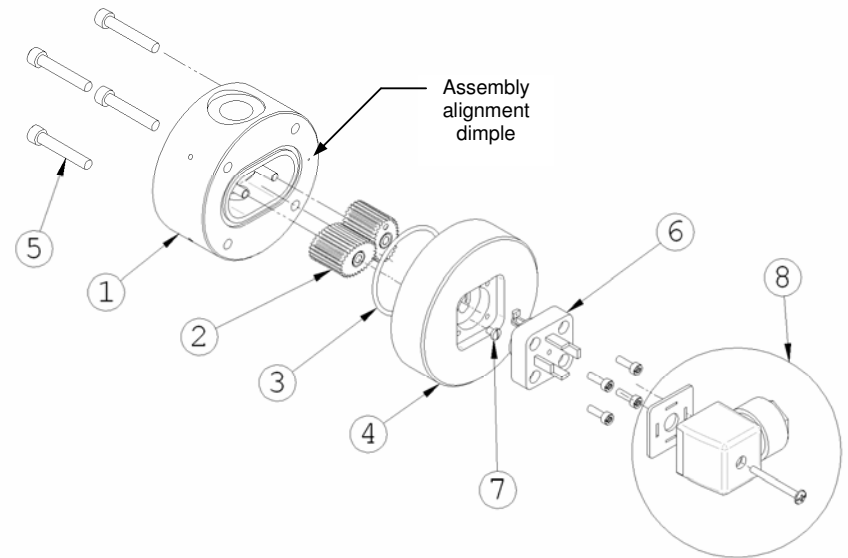

4.4 Re-assembly of meter (refer Exploded View) When replacing the rotors be very sure to have the rounded tooth ends at the bottom of the measuring chamber otherwise the rotors will be severely damaged as the meter cap (5) is fastened into place.

Re-install rotors by locating the dimple mark on the meter section which contains the rotor shafts. The shaft located closest to the dimple mark must be fitted with the driving rotor which is a rotor fitted with magnets (this applies to models OM004 & OM006 only). The magnets MUST be visible when the rotor is installed. If the second rotor also contains magnets (model OM008 only) make sure all magnets are visible when installed. Both rotors will only engage correctly if fitted precisely at an orientation of 90 degrees to each other. Rotate the rotors slowly by hand to ensure they are correctly fitted at the same time check the rotor shafts & rotor bearings for wear.

Fit the O-ring into the groove and assemble the two parts of the meter ensuring the dimples on each section (1 & 5) are aligned.

Fit the body cap screws (3) and tighten using a 1,3,2,4 sequence then torque in the same sequence to 3.5 Nm. This sequence and procedure ensures the meter bodies are assembled correctly and evenly. Fit the pulse output board, DIN plug assembly or instrument as appropriate.

5.0 Fault Finding Pulse meters have two distinct sections: the mechanical wetted section housing the rotors and the electrical section housing the pulse output board. Meters fitted with integral instruments have these two sections plus the instrument. The aim of fault finding is to trace the source of the fault to one of these sections. If a fault is traced to an instrument section, refer to the relevant instruction manual.

Below are basic fault finding steps. Also refer to Trouble Shooting Guide on following page.

Step 1 - Check application, installation and set up.

Refer to Mechanical Installation section for installation and application factors that may effect the meter operation including pulsation and air entrainment or incorrect meter selection including incorrect flow rate, temperature and pressure or materials compatibility. Refer to Electrical Installation for correct wiring.

Step 2 - Check for blockages.

The most common cause of fault/unsatisfactory meter operation, particularly for new or altered installations, is due to blockage within the system or meter caused by foreign particles such as weld slag, sealing tape or compound, rust, etc.

Step 3 - Ensure flow is present.

No flow or lower than normal minimum flow may be attributed to a blocked strainer, jammed or damaged rotors within the flowmeter, malfunctioning pump, closed valves or low liquid level in feeder tank.

Step 4 - Ensure oval gears within meter are rotating.

Rotation of the oval gears can be heard by holding a screw driver blade to the meter body and pressing the handle hard against the ear lobe. If necessary test the meter with the flow turned off and turned on to familiarize yourself with the audible rotation signature.

Step 5 - Ensure pulses are being generated during flowing conditions.

A multimeter is often not fast enough to distinguish the pulse train from the reed switch or Hall Effect sensor. An oscilloscope will allow you to view the output pulse train. When viewing the Hall effect sensor pulse ensure a pull up resistor is installed between the pulse output and the supply voltage (refer electrical installation).

Step 6 - Confirm Instrument Operation.

If an associated instrument is connected to the flowmeter confirm its operation by simulating a pulse input onto the flow input terminals. In most instances a contact closure on the flow input terminals is an adequate simulation.

5.1 TROUBLE SHOOTING

Symptom	Possible cause	Solution
Meter readings are high	1. Output signal interference	1. Ground shield of signal cable 2. Re-route cable from high electrical energy sources
	2. Entrained air or gas	1. Remove source of air or gas entrapment 2. Install an upstream air eliminator
	3. Pulsating flow from reciprocating style pump	1. Increase back pressure on pump 2. Install a fast response one way check valve 3. Install a surge arrestor between pump & meter 4. Re-calibrate meter in situ to compensate for pulsations 5. Change pump style to smooth delivery type pump
Meter readings are low	1. Damaged or worn rotors	1. Inspect, repair, clean or replace rotors
	2. Damaged or worn measuring chamber	1. Inspect measuring chamber for damage - repair 2. Check concentricity of rotor shafts within chamber
	3. Output signal interference	1. Ground shield of signal cable 2. Re-route cable from high electrical energy sources 3. Check all electrical terminations & wires for continuity.
No output from meter	1. Rotors fouled	1. Check that rounded teeth are towards base of chamber 2. Check for obstruction due to foreign particles 3. Clean, repair or replace rotors
	2. Meter incorrectly reassembled	1. See instructions for reassembly of meter with particular emphasis on positioning of rotors & magnets
	3. No output from output board	1. Check terminal connections & solder joints 2. Ensure dc voltage is available at Vdc & 0V and receiving instrument is fitted with a pull up resistor 3. Replace output board
Not reading on readout instrument	1. Faulty receiving instrument	1. Check DIP switch settings & program data 2. Check terminal connections & electrical continuity 3. Repair / replace receiving instrument