

Series 7000 torque sensors



Technical data

- Measuring range in Nm (+/-): 3.000; 5.000
- Rotational speed: ≤ 3.600 rpm
- Accuracy: $\leq \pm 0,5 \%$
- Temperature range: -40 °C to $+85$ °C
- Protection class: IP50, IP65
- Output signals: 0-10 V/4-20 mA/CAN-Bus/USB
- Output frequency: 2.500 Hz

Your advantages

- Made in Germany (nearby Munich, Bavaria)
- Fast availability
- Best price-performance ratio
- Integrated electronic (Plug & Play)
- Contactless measurement system
- Including 5 m cable and calibration certificate

Short description

The series 7000 is extremely robust and the most reliable torque measuring system.

This series is mainly used in test facilities, automotive engineering (agriculture and off-highway), process monitoring and quality control.

Transmitted torque can be measured statically and dynamically in real time. Additional to the flange system it is possible to order a variety of different shafts and bushes as accessories. Each sensor can be configured individually with a lot of extras, such as angle sensor, speed sensor and protection class IP65.

Series 7000 offers a wide range of output signals such as 0-10 V, 4-20 mA, CAN-Bus or USB. USB is offered including a special software to show data in real time. Hydrotechnik also offer a large range of multi channel data logging instruments.

The sensor is provided as a complete unit with integrated evaluation electronic, including 5 m cable and calibration certificate.

Model series 7000

Model series 7000	Unit	Nominal torque bidirectional (+/-)	Max. load bidirectional (+/-)	Rotational speed [rpm]
NCTE-Flange	[Nm]	3.000 - 5.000	-	3.600
Customized-Flange	[Nm]	Customized to 8.000	-	3.600

The maximum permissible dynamic axial tensile load is 10.000 Nm.

Additional shafts and bushes for NCTE-Flange sensors (Accessories)

Additional shafts for NCTE-Flange sensors	Order number	screws / steel grade	Max. dynamic constant load [Nm]
Shaft 6 teeth (1 3/4")	400012-ATM224	8 x M12 steel grade 12.9	4.500
Shaft 6 teeth (1 3/8")	400012-ATM220	8 x M12 steel grade 12.9	2.500
Shaft 20 teeth (1 3/4")	400012-ATM226	8 x M12 steel grade 12.9	5.000
Shaft 21 teeth (1 3/8")	400012-ATM222	8 x M12 steel grade 12.9	3.000

Additional bushes for NCTE- Flange sensors	Order number	screws / steel grade	Max. dynamic constant load [Nm]
Bush 6 teeth (1 3/4")	400012-ATM225	8 x M12 steel grade 12.9	5.000
Bush 6 teeth (1 3/8")	400012-ATM221	8 x M12 steel grade 12.9	5.000
Bush 20 teeth (1 3/4")	400012-ATM227	8 x M12 steel grade 12.9	5.000
Bush 21 teeth (1 3/8")	400012-ATM223	8 x M12 steel grade 12.9	5.000

Technical characteristics

No.	Model	Unit	Series 7000	
	Accuracy class ¹		0,5	
		Unit	Value	
1	Linearity deviation incl. hysteresis	%ME ²	< ±0,5	
2	Rotational Signal Uniformity (RSU)		< ±0,5	
3	Repeatability		< ±0,05	
Output signal in general		Unit	Value	
4	Frequency range, -3dB point, Bessel characteristics	Hz	1.000	
	Digital output; CAN-Bus		10 (max. 1.000) ³	
5	Analog signal	V mA	0 ... 10	4 ... 20
6	Signal at torque = Zero ⁴	V mA	5	12
7	Signal at positive nominal torque ³	V mA	9	19
8	Signal at negative nominal torque ³	V mA	1	5
9	Calibration parameter (normed) ³	V/Nm mA/Nm	4 V/Measurement range	8 mA/Measurement range
10	Error output	V mA	10	22
11	Output resistance	Ω	43	
Effect of temperature		Unit	Value	
12	Zero point drift over temperature	%/10 K	< 0,5	
13	Signal drift over temperature within nominal temperature range	%/10 K	< 0,5	
Power supply		Unit	Value	
14	Supply voltage	VDC	9 ... 28	
15	Current consumption (max.)	mA	100	
16	Start-up peak	mA	< 100	
17	Absolute max. supply voltage	VDC	30	

¹ The accuracy class implies that taken separately both the linearity deviation as well as the rotational signal uniformity are either lower than or equal to the value of the accuracy class.

² %ME: related to a full scale measurement range.

³ Individual changes possible. CAN-Bus up to 1.000 Hz.

⁴ Please check the exact data at the sensors calibration certificate.

	General information	Unit	Value
18	Protection class according to EN 60529 ⁵	IP	50/65
19	Reference temperature	°C	+15 ... +35
20	Operational temperature range	°C	-40 ... +85
21	Storage temperature range	°C	-40 ... +85
22	EMV	-	EN 61000/EN 55011
23	Weight	g	min 8.000

Dimensions

Dimensions of series 7000 including NCTE-Flanges.

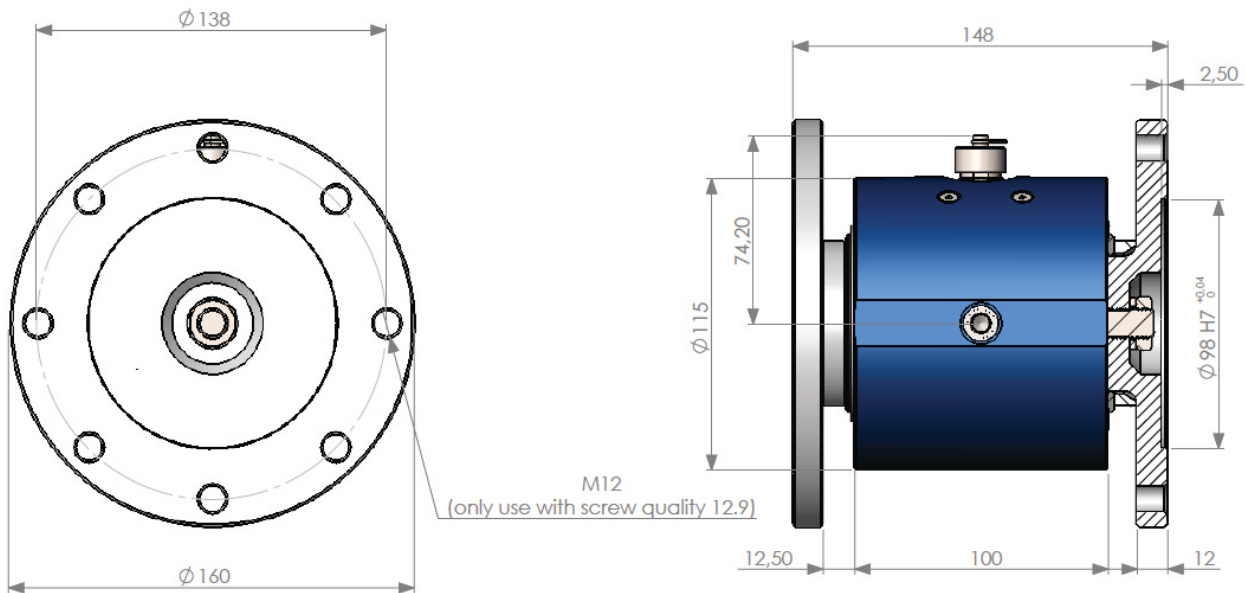

Flange has to be fixed by eight screws M12 steel grade 12.9 and 155 Nm.

The screws must be checked before each use.

⁵ Wiring connected.

Additional shafts and bushes for NCTE-Flange sensors (Accessories)

Please feel free to contact your NCTE sales team for additional information. Email: sales@ncte.de or Phone: +49 89 66 56 19 17.

PTO shaft 6 teeth ($1 \frac{3}{4}''$), ≤ 4.500 Nm maximum dynamic constant load

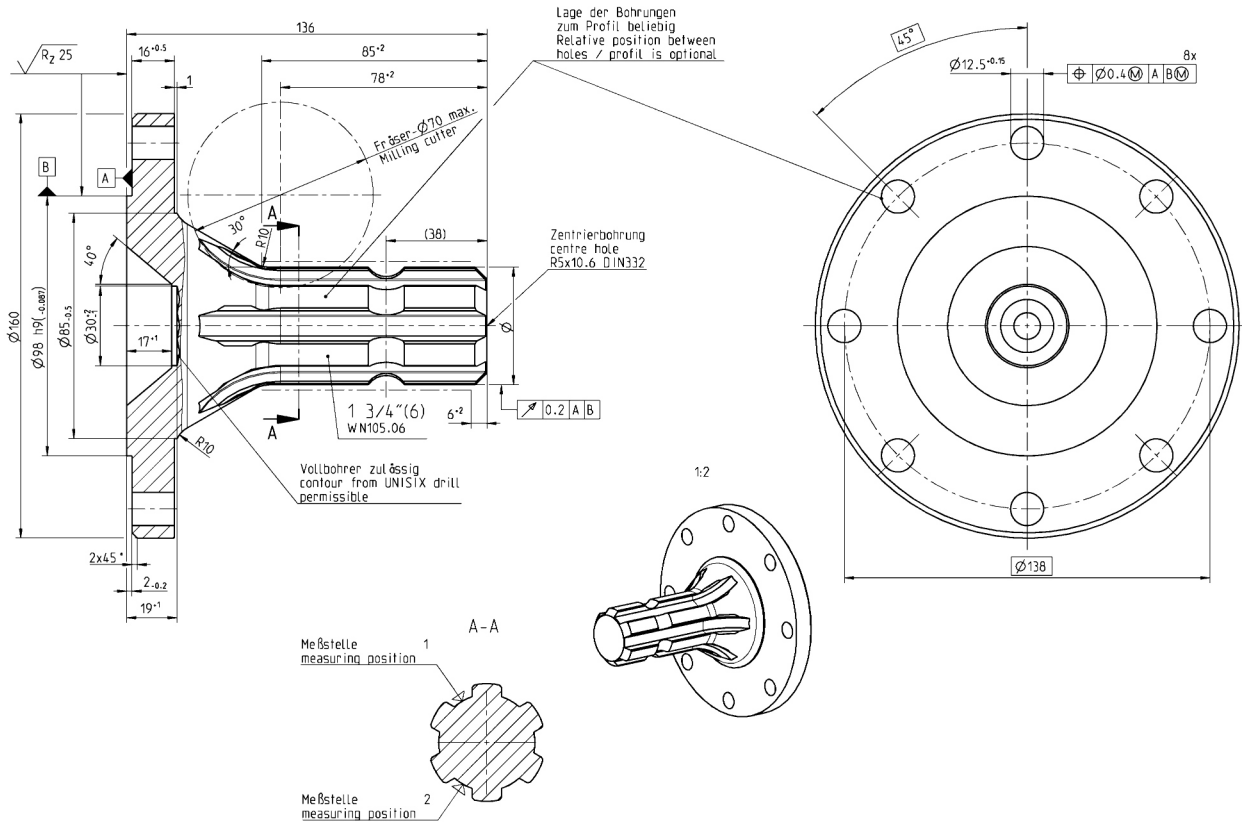

PTO shaft 6 teeth (1 3/8"), ≤ 2.500 Nm maximum dynamic constant load

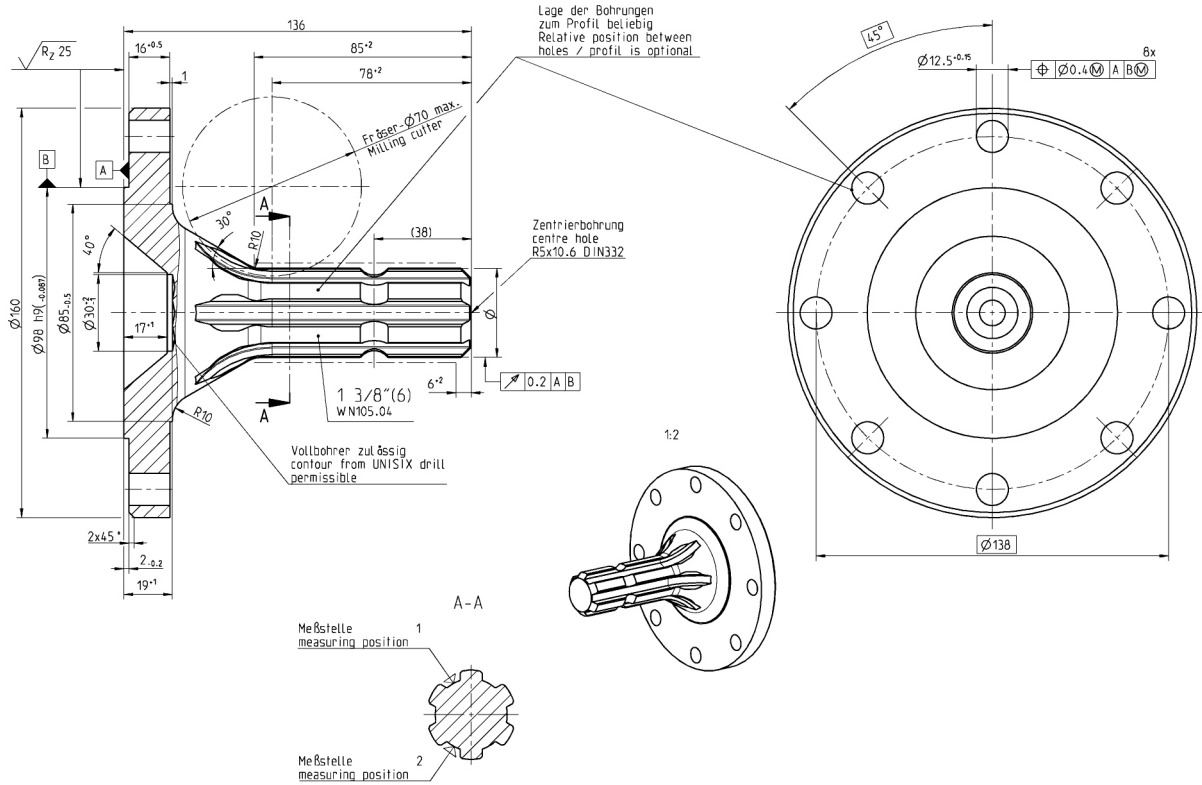

PTO shaft 20 teeth (1 3/4"), ≤ 5.000 Nm maximum dynamic constant load

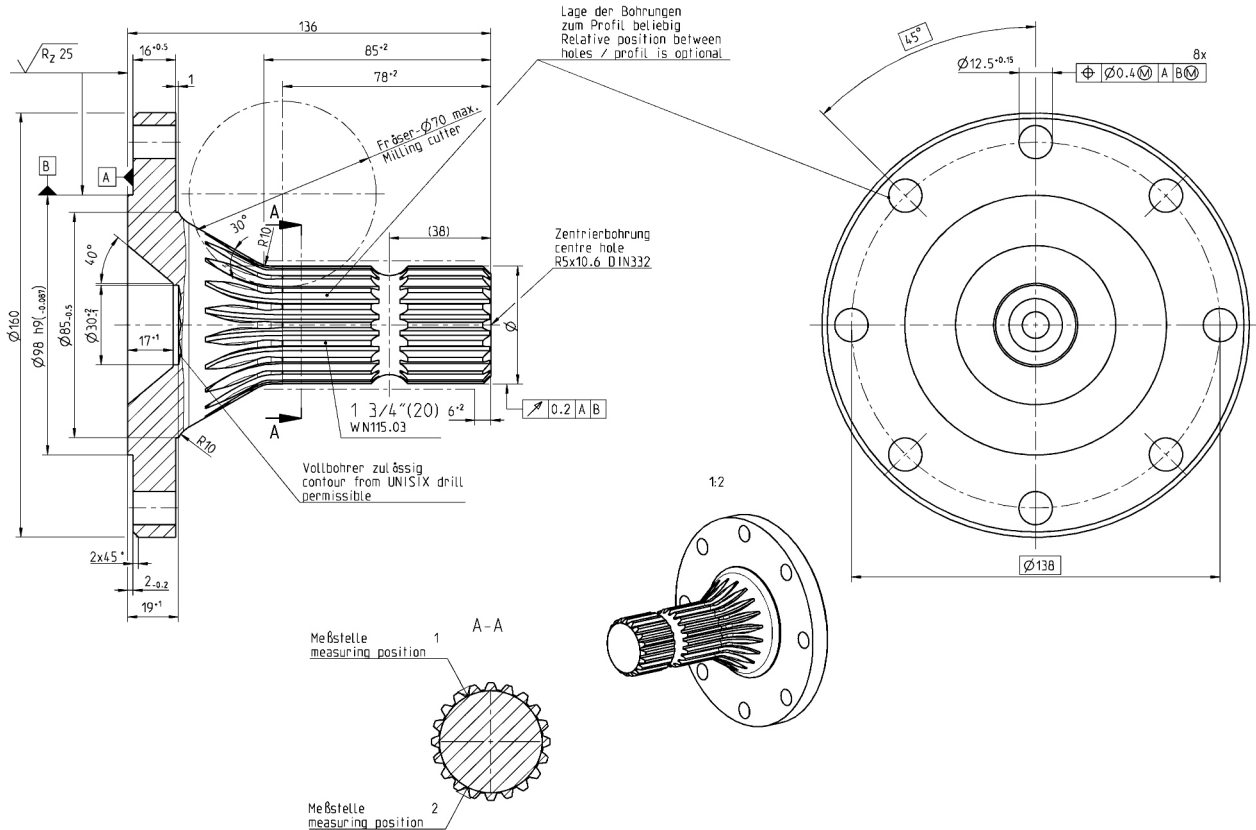

PTO shaft 21 teeth (1 3/8"), ≤ 3.000 Nm maximum dynamic constant load

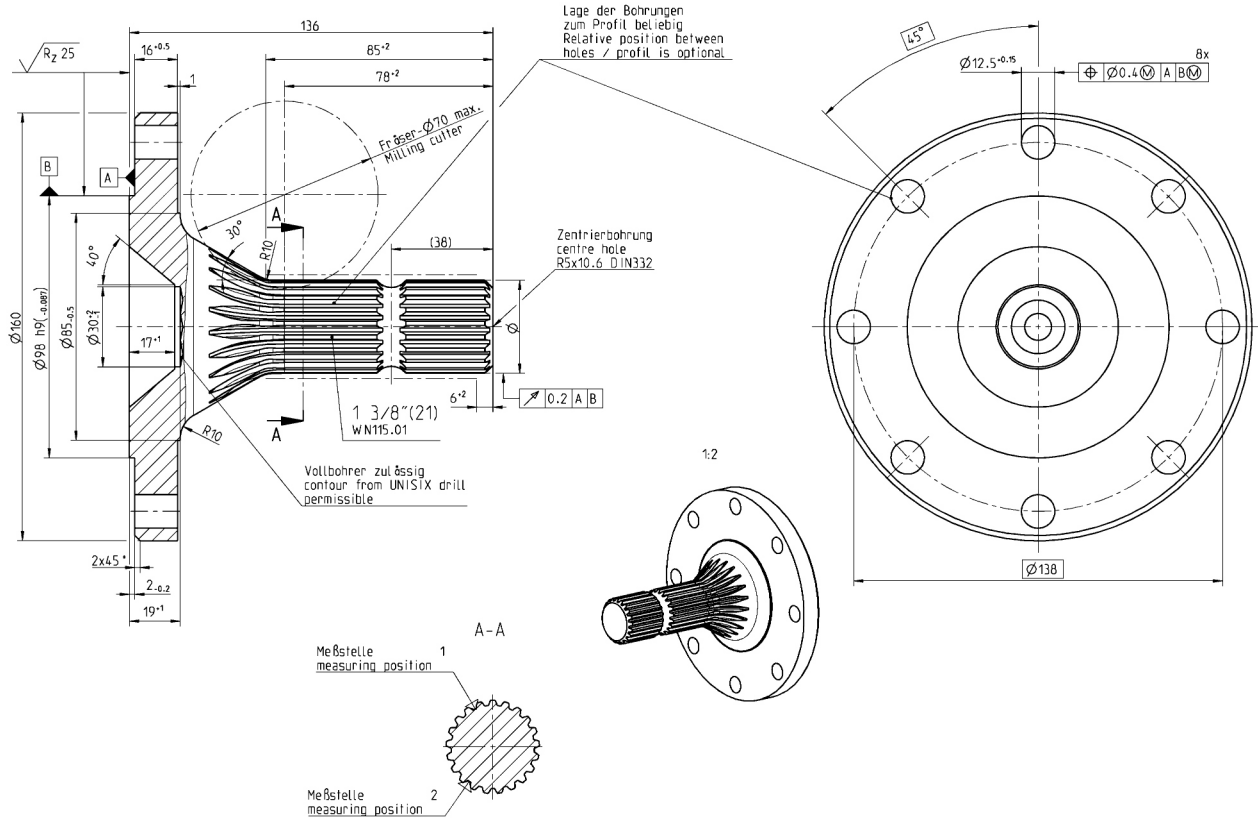

PTO bush 6 teeth (1 3/4"), ≤ 5.000 Nm maximum dynamic constant load

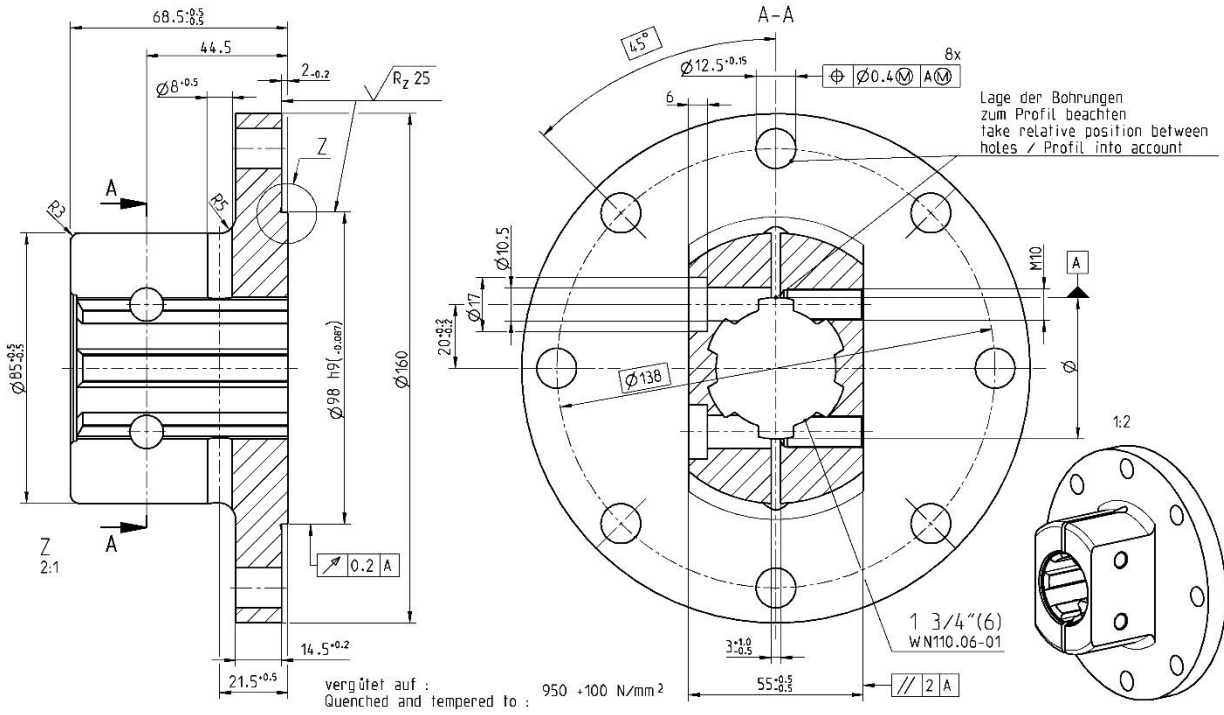

PTO bush 6 teeth (1 3/8"), ≤ 5.000 Nm maximum dynamic constant load

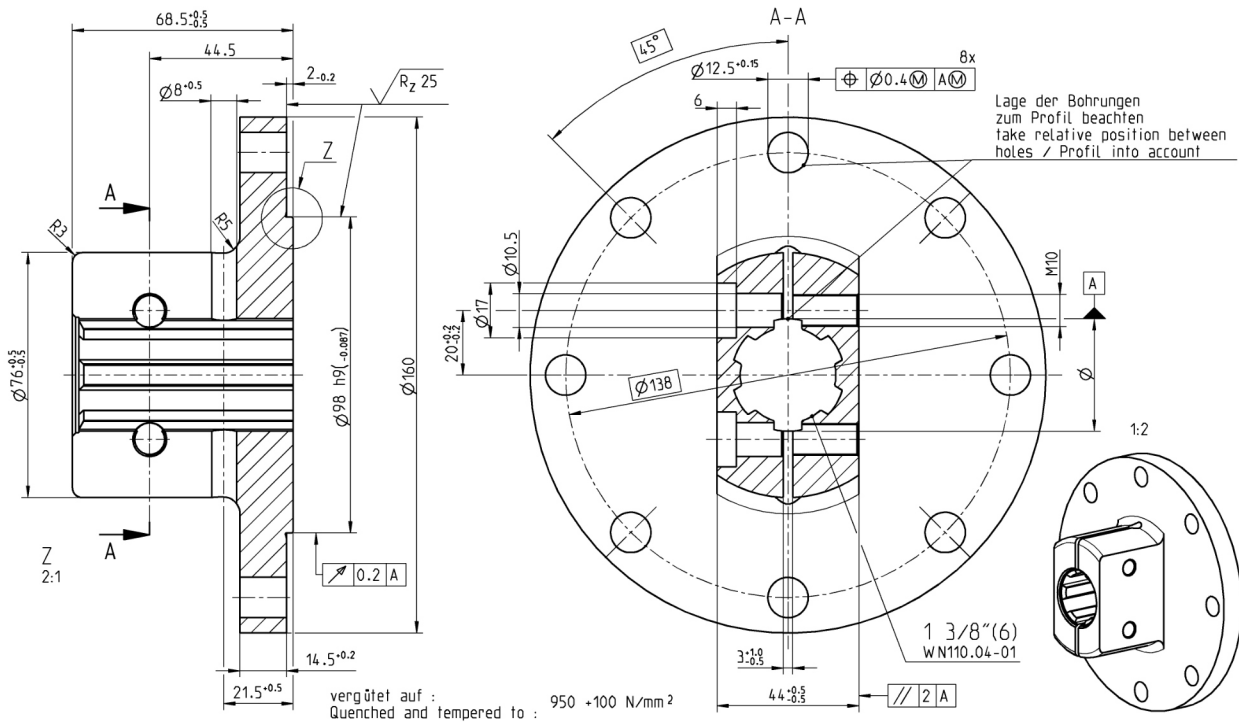

PTO bush 20 teeth (1 3/4"), ≤ 5.000 Nm maximum dynamic constant load

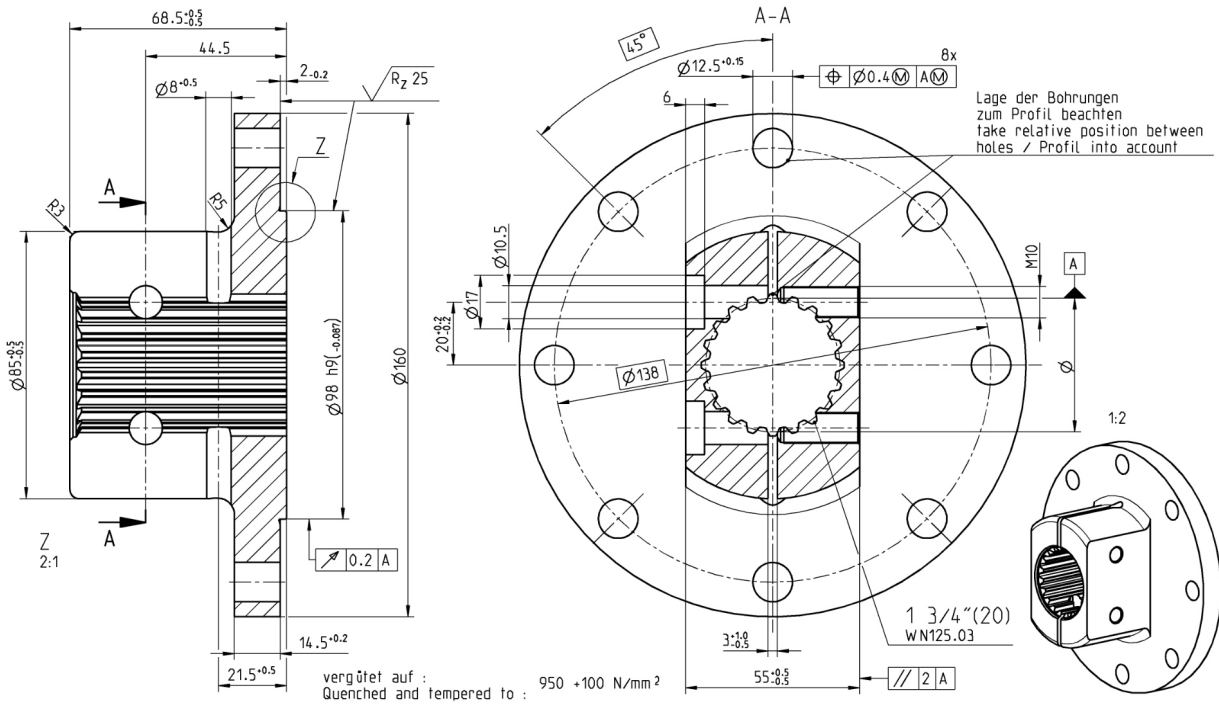

PTO bush 21 teeth (1 3/8"), ≤ 5.000 Nm maximum dynamic constant load

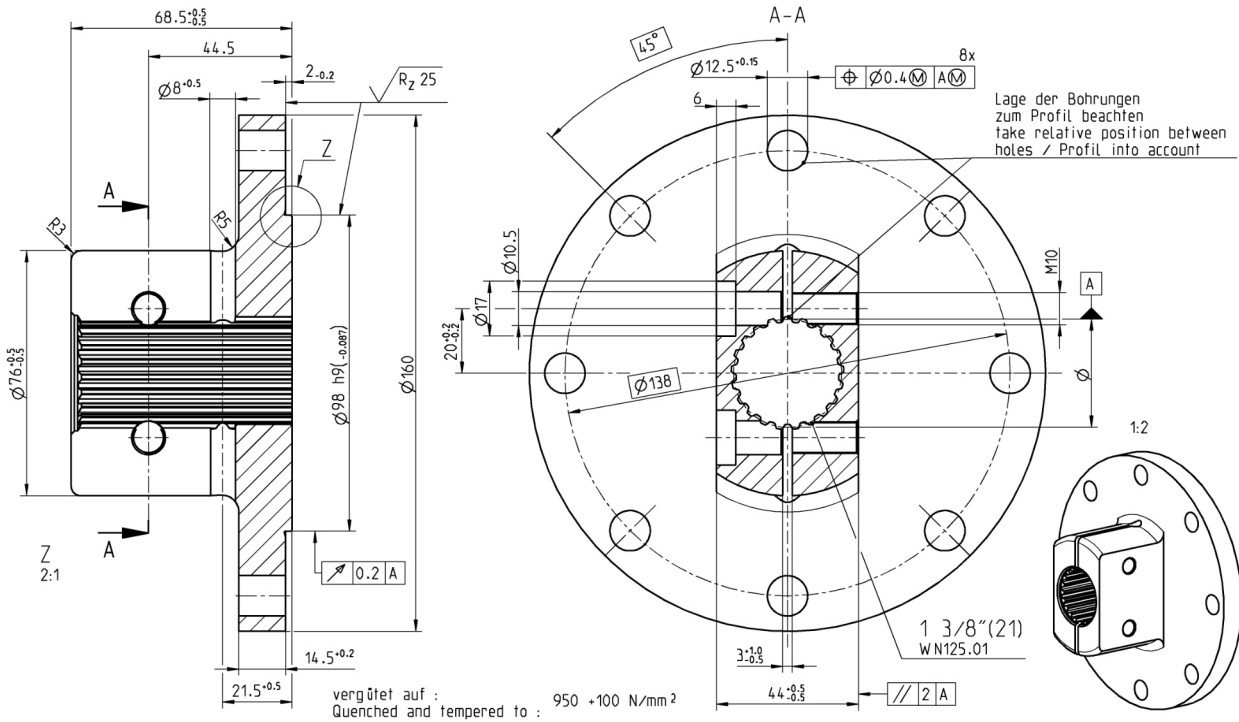

Connection plan

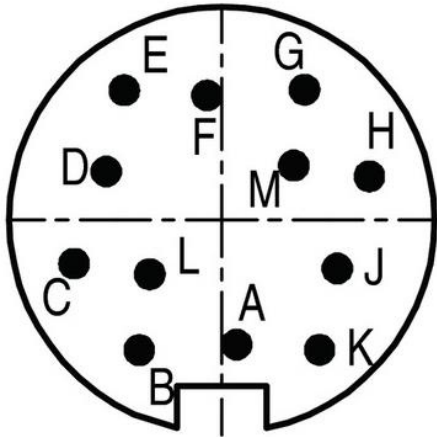

Connector
Power supply and outputs

Binder series s712-M9 connector IP67 colour coding according to DIN 47100			
Pin	Colour	Description	Value
A	White	CAN / USB	H/D-
B	Brown	CAN / USB	L/D+
C	Green	Angle channel A	0 V ... 5 V
D	Yellow	Angle channel B	0 V ... 5 V
E	Grey	Analog GND	-
F	Pink	Analog voltage Analog current	0 V ... 10 V 4 mA ... 20 mA
G	Blue	Ground GND	-
H	Red	Supply voltage VCC	9 V ... 28 V
J	Black	USB GND	-
K	Violet	-	-
L	Grey-Pink	USB	+5 V
M	Red-Blue	-	-

Connection example:

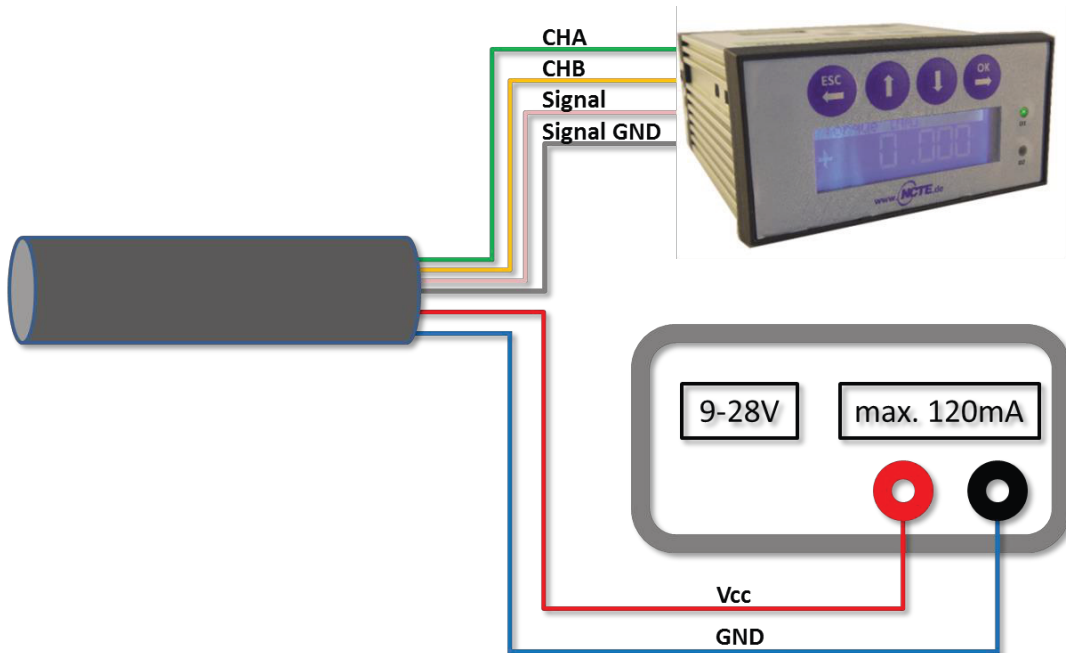

Angle sensor

Optical angle sensor with 360 CPR.

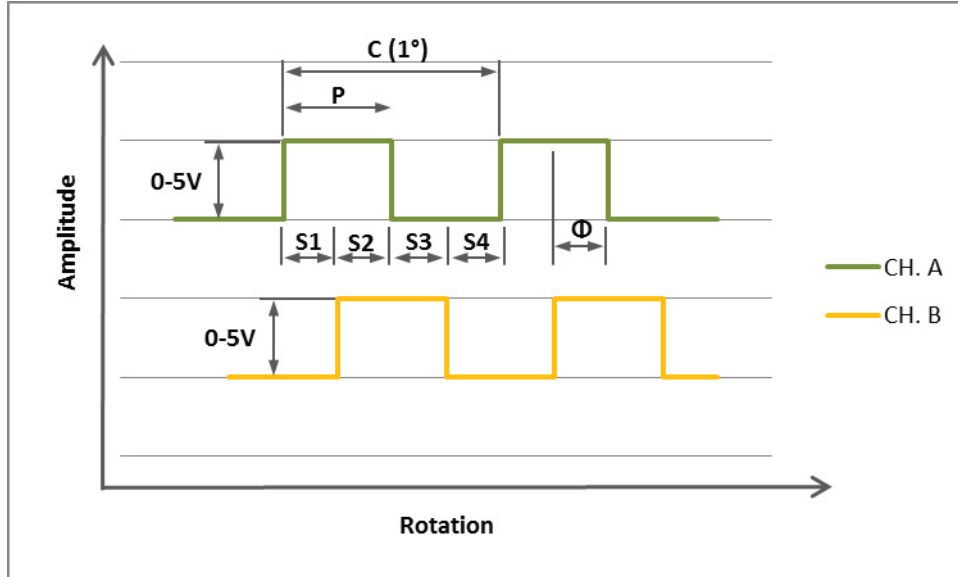

Parameter	Min.	Typ.	Max.	Units
High Level Output Voltage	2,4	5	-	V
Low Level Output Voltage	0	-	0,4	V
Parameter	Description			
C	One cycle of 360 CPR (degrees)			
P	The duration of high state of the output within one cycle			
S	The number of electrical degrees between a transition in Channel A and the neighbouring transition in Channel B			
Φ	The number of electrical degrees between the center of high state of Channel A and the center of high state of Channel B			

Speed sensor

Magnetic (Hall Effect) speed sensor with 1 CPR or 60 CPR.

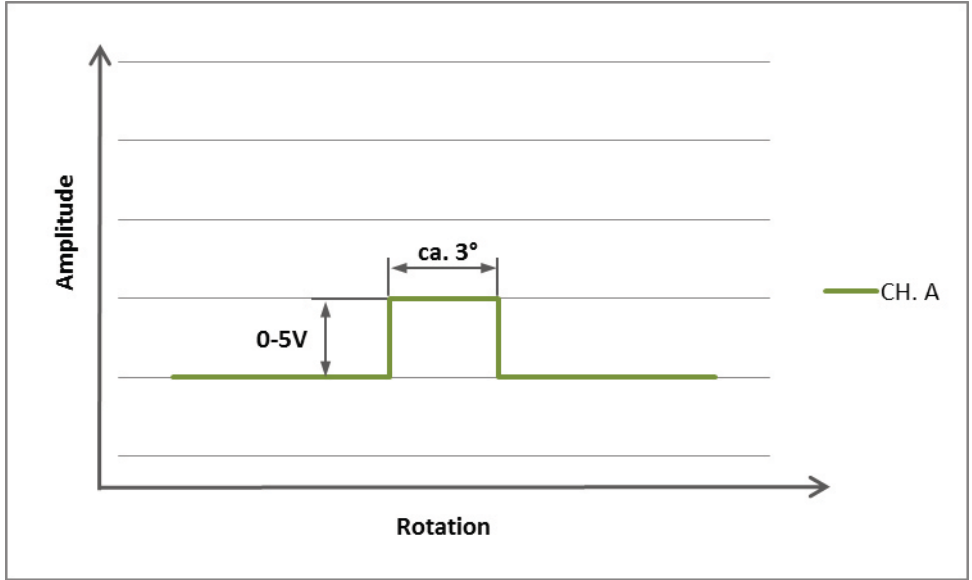

Parameter	Min.	Typ.	Max.	Unit
Operating frequency	0	-	8.000	Hz
Analog band width	20	40	-	kHz
High Level Output Voltage	2,4	5	-	V
Low Level Output Voltage	-	0	0,4	V

Order options

Series 7000 accuracy 0,5 %		Price
Measurement range		
3.000	Nm including 5 m cable and calibration certificate	
5.000	Nm including 5 m cable and calibration certificate	
XXXX	Selectable up to 5.000 Nm including 5 m cable and calibration certificate	
1st Shaft end		
0	NCTE-Flange (bolt circle 138 mm with 8 x M12)	
X	Customized	
2nd Shaft end		
0	NCTE-Flange (bolt circle 138 mm with 8 x M12)	
X	Customized	
0	Without angle sensor	
1	Angle sensor 360CPR (only with IP50)	
2	Speed sensor 1CPR	
3	Speed sensor 60CPR	
A	Voltage output 0-10 V	
S	Current output 4-20 mA	
U	USB incl. NCTE Software and 2,8 m cable	
C	CAN-Bus (not with angle sensor)	
Inverted output signal		
I	All output signals inverted	
Protection class according to EN 60529		
0	IP50	
1	IP65 (not with angle sensor)	
7000		

Accessories		Price
NCTE Readout Unit, works with all NCTE Sensors		
A	Torque sensor input: Voltage output 0-5 V and 0-10 V Order number: 400010-ATS001 1 angle encoder input, A/B USB interface, Windows software included SD card slot	
S	Torque sensor input: current output 4-20 mA Order number: 400010-ATS002 1 angle encoder input, A/B USB interface, Windows software included SD card slot	
Additional shafts for NCTE-Flange sensors		
1	400012-ATM224 PTO shaft 6 teeth (1 3/4")	
3	400012-ATM220 PTO shaft 6 teeth (1 3/8")	
5	400012-ATM226 PTO shaft 20 teeth (1 3/4")	
7	400012-ATM222 PTO shaft 21 teeth (1 3/8")	
Additional bushes for NCTE-Flange sensors		
2	400012-ATM225 PTO bush 6 teeth (1 3/4")	
4	400012-ATM221 PTO bush 6 teeth (1 3/8")	
6	400012-ATM227 PTO bush 20 teeth (1 3/4")	
8	400012-ATM223 PTO bush 21 teeth (1 3/8")	

Instruction manual

The series 7000 is extremely robust and the most reliable torque measuring system.

This series is mainly used in test facilities, automotive engineering (agriculture and off-highway), process monitoring and quality control.

Transmitted torque can be measured statically and dynamically in real time. Additional to the flange system it is possible to order a variety of different shafts and bushes as accessories. Each sensor can be configured individually with a lot of extras, such as angle sensor, speed sensor and protection class IP65.

Series 7000 offers a wide range of output signals such as 0-10 V, 4-20 mA, CAN-Bus or USB. USB is offered including a special software enables to show data in real time.

The sensor is provided as a complete unit with integrated evaluation electronic, including 5 m cable and calibration certificate.

General

Please read the instructions carefully before using it for the first time and only use the product for the intended purpose. Keep this manual for future reference to avoid any incorrect use. The instruction manual can also be downloaded as a PDF file under the following link: <http://www.ncte.com/service/downloads/>, or can be requested from our customer service at: sales@hydrotechnik.co.uk

Manufacturer

The manufacturer of the torque sensor series 7000 is:

NCTE AG

Raiffeisenallee 3

82041 Oberhaching

Germany

Tel.: + 49 (0) 89 665 619-0

Fax: + 49 (0) 89 665 619-29

EU directives and standards

The series 7000 is compliant with the European Union directives and the European Standards listed in this document. Further requirements are to be requested from the manufacturer.

Scope of delivery

The torque sensor set consists of the sensor itself (signal pick-up and signal processing integrated into sensor housing), one **connecting cable** 5 m with a **soldered plug** (binder plug no. 99-5630-15-12) and the calibration certificate.

USB-cable will be delivered in 2,80 m length.

Datasheets and instruction manuals are available at www.ncte.com.

Intended Use

Use the product only as described in the instruction manual. Any other use is considered as improper and may result in property damage or even personal injury. The manufacturer assumes no liability for damage caused by improper or incorrect use.

Installation and removal

Make sure to install the sensor shafts exactly with the proper aligned connecting shafts. The shafts end has to be attached forceless to the corresponding ones. No external axial force should be on the housing of the sensor from distortion. A maximum cable length of 5 m must not to be exceeded. Using a cable or connector other than supplied by **NCTE**, or a similar cable that is of a different length may affect the overall performance of the sensor.

The security against rotation may only occur via the M8 thread (screws M8 steel grade 12.9) on the flattening of the housing. Maximum load at the thread is 25 Nm.

Do not remove the shaft with torque applied to the sensor.

Flange has to be fixed by eight screws M12 steel grade 12.9 and 155 Nm. The screws must be checked before each use.

Offset adjustment

If required the zero point output signal (5 V/12 mA) can be adjusted by pressing the Tare-button. By factory default the sensor is set to 5 V or 12 mA at zero torque.

Interface description

Mechanical connection:

The flanges or additional adapters on both ends of the measurement shaft are intended for torque transmission.

Electrical connector:

On the sensor housing there is a 12-pin socket for the power supply and the signal output (see chapter connection plan).

Operation (in regular case or in optimal case)

Optimal measurement parameters can be achieved if the sensor is applied in accordance to the specification. By compliance with the specification the sensor works generally trouble-free and maintenance-free.

Irregular operation, measures against disturbance

The mechanical overload on the sensor (e. g. exceeding of maximum allowed torque or severe vibrations) may cause damage to the sensor and in consequence the incorrect signal output. In such cases please do not open the sensor. Contact your sales agent directly for assistance.

Commissioning

After sensor installation pay attention to the following:

- The sensor may only be operated with a shielding.
- Switch on the power supply unit and check the supply voltage. Peak voltage must be avoided! Be sure to verify the power supply voltage before connecting the sensor!
- Connect the sensor to the power supply unit by using the delivered cable.
- Connect the sensor output to a high-resistance device such as an A/D converter, oscilloscope, PC measurement board. The sensor should be in mechanical unloaded state while connecting it.

Handling and transportation

By handling, storage and transportation keep the sensor away from magnetic or electromagnetic fields which may exceed the maximal intensity defined from EMC (chapter technical characteristics) for instance degaussing machines.

Precautions

- Do not open the sensor housing under any circumstances.
- Do not remove or loosen the locking rings on the shaft ends.
- Do not loosen or tighten the flange-mounting nut of the socket-connector (chapter dimensions).
- Use only a separate power supply for the sensor.
- Use the sensor only according to the specification (chapter technical characteristics).



**Caution: In long-term usage Sensor with protection class IP65
can reach 90 degree Celsius.
Please be careful and use protection!**

Maintenance and overhaul

As part of your testing and measuring equipment management, we recommend regular checking of your testing and measuring equipment. Please also observe the corresponding standards and guidelines.

Recommended maintenance plan

Recalibration	12 month
Control of wiring, plug and shaft	12 month

Repairs

Repairs must be carried out exclusively by authorised personnel only. In case of service, please contact your agent to organise an RMA number for return of any equipment.

Disposal

Dispose the product and all associated components via an authorized waste disposal company. Please observe the currently applicable regulations. If in doubt, ask your disposal centre for environmentally friendly disposal.

Service-Hotline

Phone: +44 (0) 115 900 3550
Email: sales@hydrotechnik.co.uk

Fax: +44 (0) 115 970 5597