



Technical data

- Nominal torque: 50 Nm to 2.000 Nm, bidirectional
- Rotational speed: ≤ 10.000 rpm
- Accuracy: $\pm 0,2 \%$
- Temperature range: -40 °C to $+85$ °C
- Protection class: IP50
- Output signals: 0-10 V/4-20 mA
- Output frequency: 2.500 Hz

Your advantages

- Made in Germany (nearby Munich, Bavaria)
- Delivery ex warehouse (< two weeks)
- Best price-performance ratio
- Integrated electronic (Plug & Play)
- Contactless measurement system
- Including 5 m cable and calibration certificate

Short description

The series 3000 covers the accurate and reliable professional torque measurement technology.

This series is mainly used in laboratory, test facilities, trials, medical engineering, process monitoring and quality control.

Transmitted torque can be measured statically and dynamically in real time. Shaft is available as Round shaft and Square shaft. Each sensor can be configured individually with a lot of extras, such as angle sensor and signal outputs.

Series 3000 offers different output signals such as 0-10 V, 4-20 mA.

The sensor is provided as a complete unit with integrated evaluation electronic, including 5 m cable, keystones (Round shaft) and calibration certificate.

Model series 3000

Model series 3000 round shaft	Unit	Nominal torque bidirectional (+/-)	Max. load bidirectional (+/-)	Rotational speed [rpm]
Ø 15 mm	[Nm]	50	150	10.000
		100	150	
Ø 25 mm		250	750	8.000
		500	750	
Ø 40 mm		1.000	3.000	5.000
		2.000	3.000	

Model series 3000 square shaft	Unit	Nominal torque bidirectional (+/-)	Max. load bidirectional (+/-)	Rotational speed [rpm]
⅜ inch	[Nm]	50	150	10.000
		100	150	
¾ inch		250	750	8.000
		500	750	
1 inch		1.000	3.000	5.000
		2.000	3.000	

Load characteristics

Model series 3000 measuring range	Unit	Axial force [N] ¹	Lateral limit force [N]	Bending limit moment [Nm]
50 and 100	[Nm]	2.300	300	41,7
250 and 500		7.000	800	176
1.000 and 2.000		24.000	2.000	700

Each type of irregular stress can only be permitted with its given limit value (bending moment, lateral force or axial force, exceeding the nominal torque) if none of the others can occur. Otherwise the permitted limits must be reduced. If for instance 30 % of the limited bending moment and also 30 % of the limited lateral force are present, only 40 % of the limited axial force are permitted, provided that the nominal torque is not exceeded.

¹ Direct acting axial force on the shaft. If the force affects the snap ring, just 50 % of the force is permitted.

Technical characteristics

No.	Model	Series 3000	
	Accuracy class ²	0,2	
		Unit	Value
1	Linearity deviation incl. hysteresis	%ME ³	< ±0,2
2	Rotational Signal Uniformity (RSU)		< ±0,2
3	Repeatability		< ±0,05
Output signal in general		Unit	Value
4	Frequency range, -3dB point, Bessel characteristics	Hz	2.500
5	Analog signal	V mA	0 ... 10 4 ... 20
6	Signal at torque = Zero ⁴	V mA	5 12
7	Signal at positive nominal torque ⁴	V mA	9 20
8	Signal at negative nominal torque ⁴	V mA	1 4
9	Calibration parameter (normed) ⁴	V/Nm mA/Nm	4 V/Measurement range 8 mA/Measurement range
10	Error output	V mA	10 22
11	Output resistance	Ω	62
Effect of temperature		Unit	Value
12	Zero point drift over temperature	%/10 K	< 0,2
13	Signal drift over temperature within nominal temperature range	%/10 K	< 0,5
Power supply		Unit	Value
14	Supply voltage	VDC	11 ... 28
15	Current consumption (max.)	mA	150
16	Start-up peak	mA	< 200
17	Absolute max. supply voltage	VDC	30
General information		Unit	Value
18	Protection class according to EN 60529 ⁵	IP	50/65
19	Reference temperature	°C	+15 ... +35
20	Operational temperature range	°C	-40 ... +85
21	Storage temperature range	°C	-30 ... +85
22	Bearing operating hours	h	approx. 20.000

² The accuracy class implies that taken separately both the linearity deviation as well as the rotational signal uniformity are either lower than or equal to the value of the accuracy class.

³ %ME: related to a full scale measurement range.

⁴ Please check the exact data at the sensors calibration certificate.

⁵ Wiring connected.

	Nominal rated torque M (bi-directional)	Nm	50	100	250	500	1.000	2.000
23	Weight	kg	1,4	2,5	6			
24	Moment of inertia	kg mm ²	5,9	59,5	626			
EMI/EMC		Unit	Value					
25	Tested standards							
26	EN 61000-6-3: 2007	-	Passed					
27	EN 55011: 2009 + A1: 2010 class B	-	Passed					
Load limits ⁶		Unit	Value					
28	Maximum measurable torque	%	110					
29	Maximum torque, related to nominal torque	%	300					
30	Ultimate torque	%	500					

Dimensions

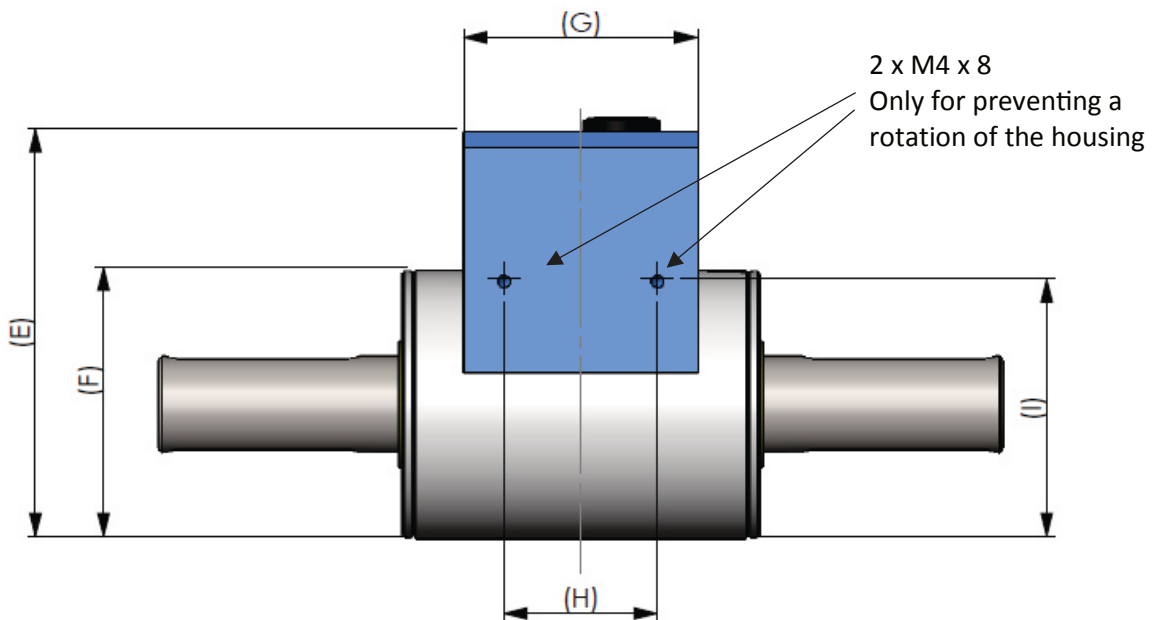

⁶ Based on the non-contact measurement principle the torque sensor is quite insensitive to bending and shearing forces. Self-aligning couplings are recommended in case of dynamic loads.

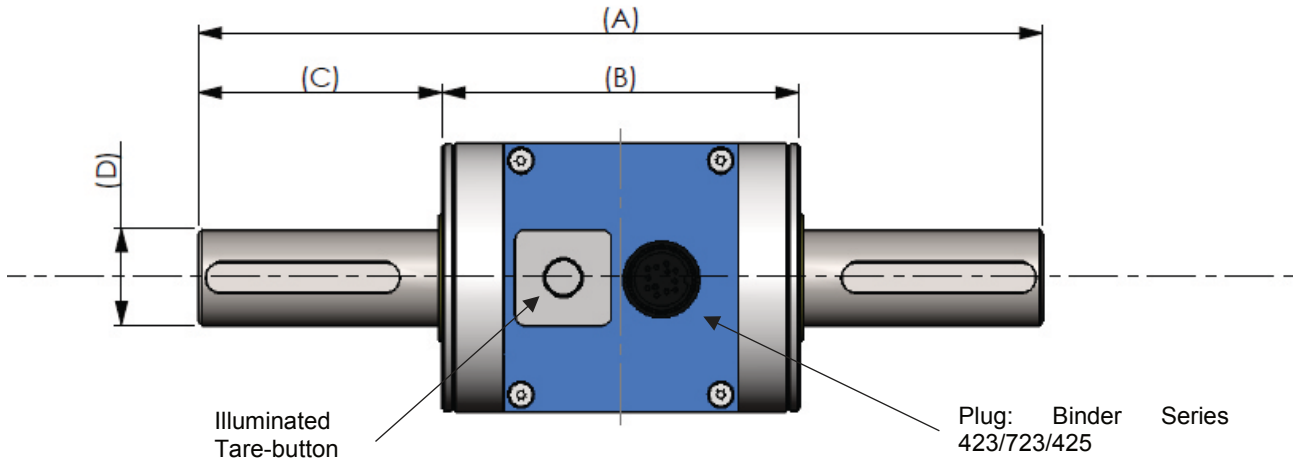

Dimensions (in mm)						
	50 Nm	100 Nm	250 Nm	500 Nm	1.000 Nm	2.000 Nm
A	160	160	220	220	350	350
B	93	93	101	101	130	130
C	33,5	33,5	59,5	59,5	110	110
D	15g6	15g6	25g6	25g6	40g6	40g6
E	96	96	106	106	126	126
F	60	60	70	70	90	90
G	61	61	61	61	80	80
H	40	40	40	40	60	60
I	57	57	67	67	87	87

Dimensions keyway [mm]				Keystones			Key stone-position
Shaft	Width	Depth	Length	Height	Length	Amount	Distance L
∅ 15 mm	5N9	3	25,5	5	25	1	130,5
∅ 25 mm	8N9	4	50,5	7	50	2	165,5
∅ 40 mm	12N9	5	90,5	8	90	2	252,0

Connection plan

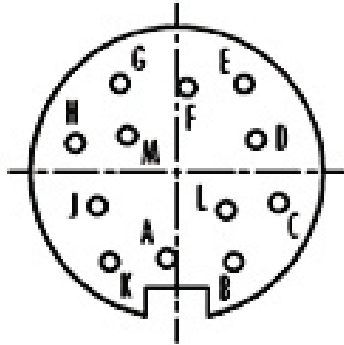

Connector
Power supply and outputs

Binder series 423/723/425 Item number: 09-0132-90-12 colour code according to DIN 47100			
Pin	Colour	Description	Value
A	White	Supply voltage V _{CC}	11 V ... 28 V
B	Brown	Ground GND	-
C	Green	Analog Out	0 V ... 10 V
D	Yellow	Analog GND	-
E	Grey	Analog Out	4 mA ... 20 mA
F	Pink	Angle Ch A	0 V ... 5 V
G	Blue	Angle Ch I	0 V ... 5 V
H	Red	Angle Ch B	0 V ... 5 V
J	Black	-	-
K	Violet	For internal use only	RX (TTL Pegel)
L	Grey-Pink	For internal use only	RX (TTL Pegel)
M	Red-Blue	Digital GND	-

Connection example:

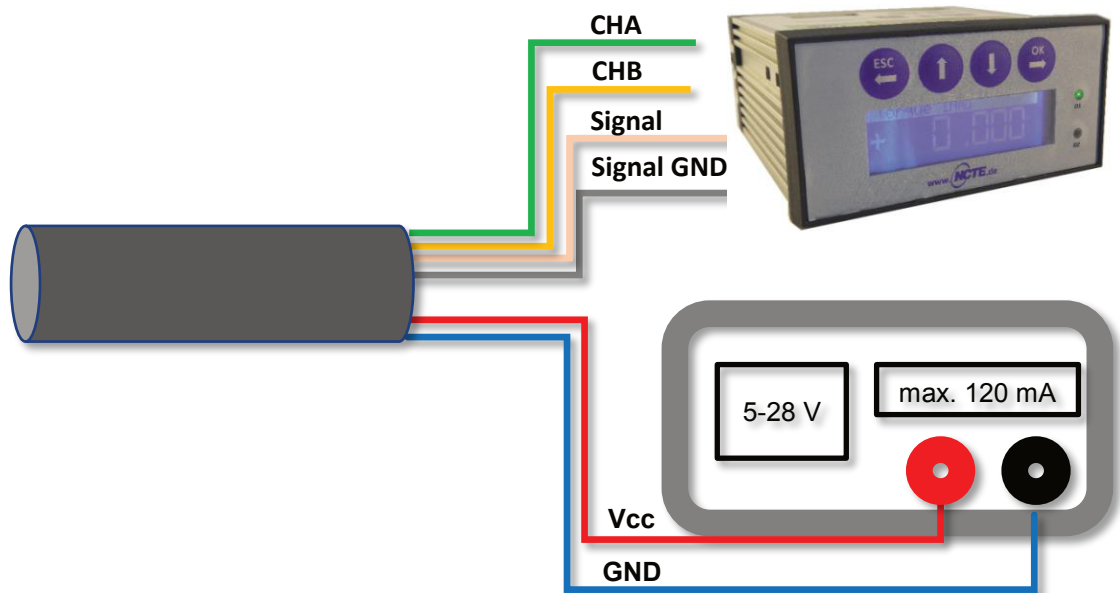

Angle sensor

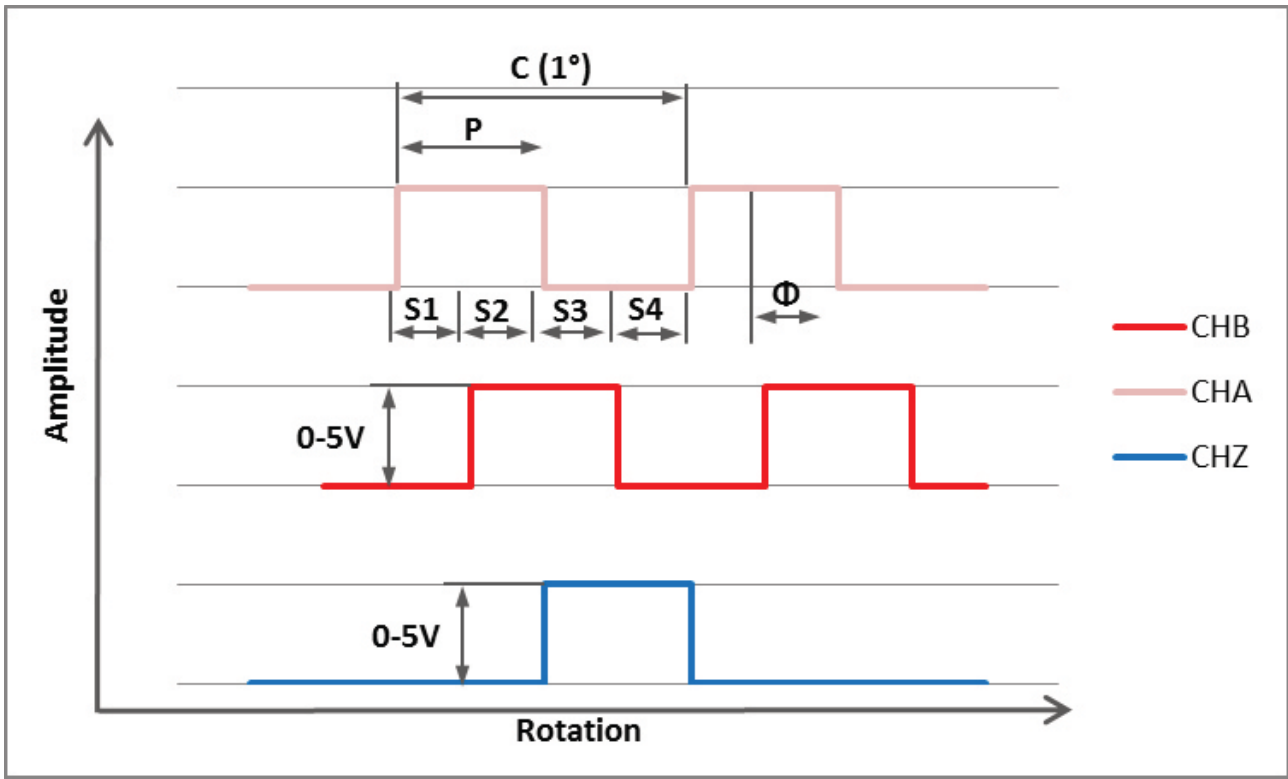

Parameter	Min.	Typ.	Max.	Units
High Level Output Voltage	2,4	5	-	V
Low Level Output Voltage	0	-	0,4	V
Parameter	Description			
C	One cycle of 360 CPR (degrees)			
P	The duration of high state of the output within one cycle.			
S	The number of electrical degrees between a transition in Channel A and the neighboring transition in Channel B.			
Φ	The number of electrical degrees between the center of high state of Channel A and the Center of high state of Channel B.			

Order options

Series 3000 accuracy 0,2 %		Price
Measurement range		
50	Nm including 5 m cable and calibration certificate	
100	Nm including 5 m cable and calibration certificate	
250	Nm including 5 m cable and calibration certificate	
500	Nm including 5 m cable and calibration certificate	
1.000	Nm including 5 m cable and calibration certificate	
2.000	Nm including 5 m cable and calibration certificate	
Angle sensor		
0	Without angle sensor	
1	Angle sensor 360CPR	
Analog output		
A	Voltage output 0-10 V	
S	Current output 4-20 mA	
Shaft ends		
0	Round shaft with keystone	
1	Square shaft (available with 50/250/1.000 Nm)	
Protection class according to EN 60529		
0	IP50	
3000		

Please feel free to contact your sales partner for additional information.

Instruction manual

Scope of delivery

The torque sensor set consists of the sensor itself (signal pick-up and signal processing integrated into sensor housing), one **connecting cable** 5 m with a **soldered plug** (binder plug no. 99-0426-10-08), **key stones** (round shaft) and the calibration certificate.

Datasheets and instruction manuals are available at on request

Installation and removal

Make sure to install the sensor shafts exactly with the proper aligned connecting shafts. The key stone adapter/square endings of the connecting shafts are to be attached forceless to the corresponding ones of the sensor. No external axial force should be on the housing of the sensor from distortion. A maximum cable length of 5 m must not to be exceeded. Using a cable or connector other than supplied by **NCTE**, or a similar cable that is of a different length may affect the overall performance of the sensor.

Do not remove the shaft with torque applied to the sensor.

Offset adjustment

If required the zero point output signal (5 V) can be adjusted by pressing the Tare-button. By factory default the sensor is set to 5 V at zero torque.

Interface description

Mechanical connection:

The key stone adapters on both ends of the measurement shaft are intended for torque transmission.

Electrical connector:

On the sensor housing there is a 8-pin socket for the power supply and the signal output (chapter connection plan).

Operation (in regular case or in optimal case)

Optimal measurement parameters can be achieved if the sensor is applied in accordance to the specification. By compliance with the specification the sensor works generally trouble-free and maintenance-free.

Irregular operation, measures against disturbance

The mechanical overload on the sensor (e. g. exceeding of maximum allowed torque or severe vibrations) may cause damage to the sensor and in consequence the incorrect signal output. In such cases please do not open the sensor. Contact your sales partner directly for assistance.

Commissioning

After sensor installation pay attention to the following:

- Switch on the power supply unit and check the supply voltage. Peak voltage must be avoided! Be sure to verify the power supply voltage before connecting the sensor!
- Connect the sensor to the power supply unit by using the delivered cable.
- Connect the sensor output to a high-resistance device such as an A/D converter, oscilloscope, PC measurement board. The sensor should be in mechanical unloaded state while connecting it.

Tare function and error indication:

Series 3000 contains a LED button on the housing surface. Pressing the button will set the signal output to 5 V. The illumination of the button serves as a function/malfunction indicator.

Functional indicator:

LED off: missing power supply or sensor is damaged
 LED on: Sensor is ready.

Error indicator:

LED flashes: The sensor is not ready.

Flashing of LED can have several possible causes. Various causes are interpreted through a flash code. After each flash code the LED makes a short pause before repeating the code.

2x flashing: Magnet field sensors defective. 4x flashing: Electronics defective.

Shaft coating

The shafts are protected on both sides with a film of anticorrosion wax. We recommend to leave the protection permanent. As far as technologically needed, the coating can be removed with spirit/ethanol

Handling and transportation

By handling, storage and transportation keep the sensor away from magnetic or electromagnetic fields which may exceed the maximal intensity defined from EMC (chapter technical characteristics) like degaussing machines.

Precautions

- Do not open the sensor housing under any circumstances.
- Do not remove or loosen the locking rings on the shaft ends.
- Do not loosen or tighten the flange-mounting nut of the socket-connector (chapter dimensions).
- Use only a separate power supply for the sensor.
- Use the sensor only according to the specification (chapter technical characteristics).

Service and maintenance

Recommended maintenance plan

Recalibration	12 month
Control of wiring, plug and shaft	12 month

Service-Hotline: Phone: +44 (0) 115 900 3550 Email:
 sales@hydrotechnik.co.uk