

SMART DIFFERENTIAL PRESSURE TRANSMITTER HDPM-10



- ✓ 4...20 mA output signal + HART protocol (special version: 0...20 mA or 0...5 mA output signal + HART protocol)
- ✓ Display with backlight
- ✓ SIL 2 certificate
- ✓ Intrinsic safety certificate (ATEX, IECEx)
- ✓ Explosion proof certificate (ATEX, IECEx)
- ✓ PED Conformity (97/23/EC)
- ✓ Programmable zero range, shift, characteristic and damping ratio with local panel keys
- ✓ Static pressure limit up to 700bar
- ✓ Accuracy 0,075% (0,05% on request)
- ✓ Marine certificate – DNV, BV
- ✓ Gold plated diaphragms
- ✓ Wetted parts material 316L/Hastelloy C276

up to 5 years warranty

static pressure limit up to 700 bar

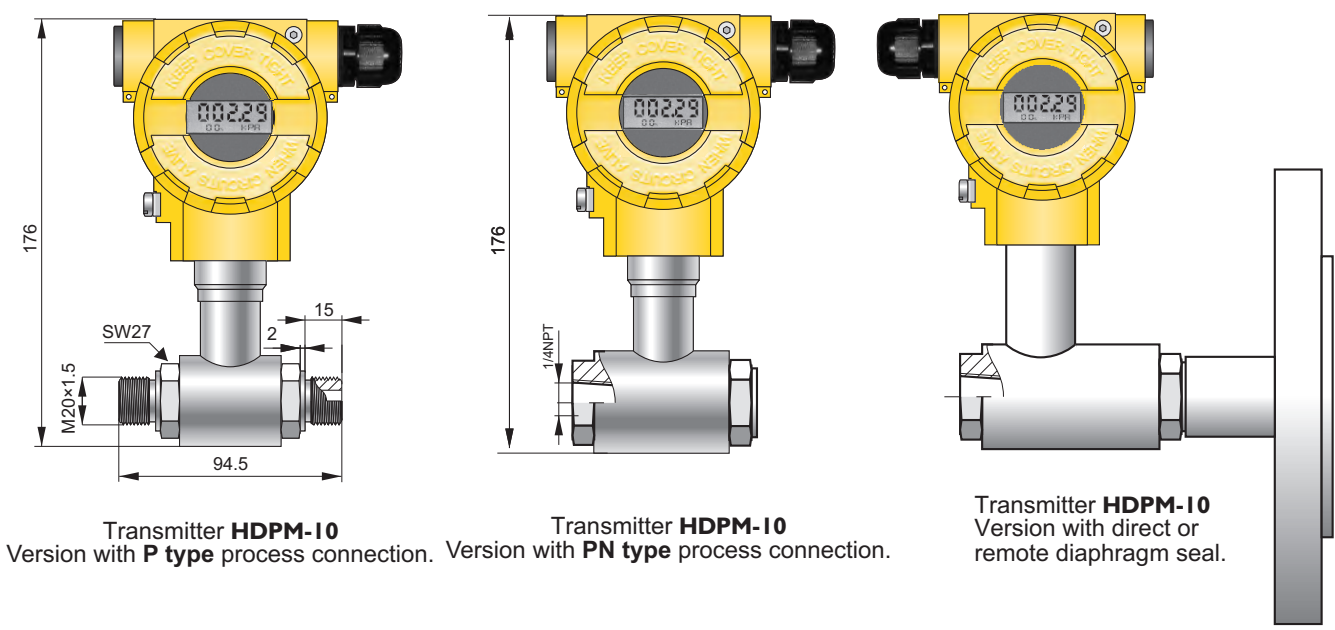
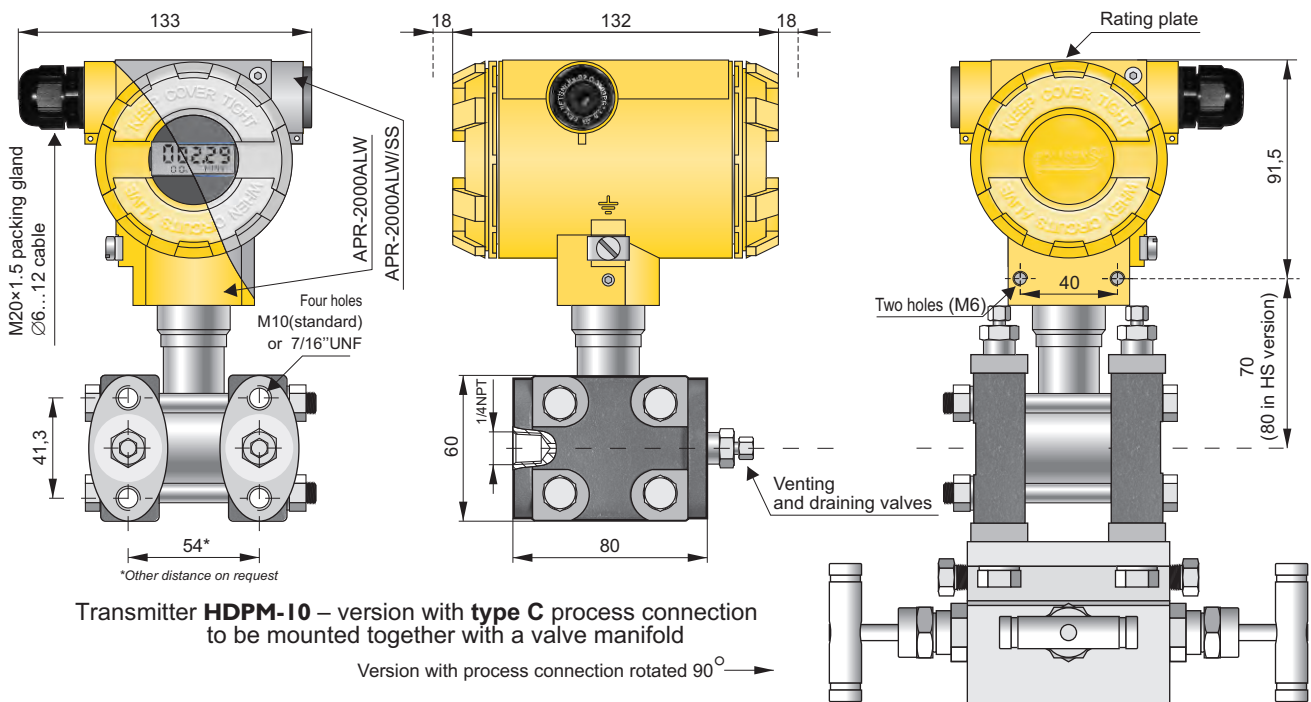

Application and construction

The HDPM-10 transmitter is applicable to the measurement of differential pressure of gases, vapours and liquids. The active element is a piezoresistant silicon sensor separated from the medium by separating diaphragms and a specially selected type of manometric fluid. The special design of the active sensing element ensures that it is able to withstand pressure surges and overloads of up to 250/320/413/700 bar. The casing is made of aluminium alloy cast or 316SS stainless steel, degree of protection IP66/IP67. The design of the casing enables the use of a local display, rotation of the display, rotation of the casing by 0–340° relative to the sensor, and a choice of cable direction.

Communication and configuration

The communication standard for data interchange with the transmitter is the Hart protocol. The data interchange with the transmitter enables users to:

Communication with the transmitter is carried out with:

- a KAP-03, KAP-03Ex communicator
- some other Hart type communicators(*)
- a PC using an HART/USB converter and Raport 2 configuration software.

(*) .eddl files available on www.aplisens.com.

- identify the transmitter
- configure the output parameters:
 - measurement units and the values of the start points and end points at the measurement range
 - damping time constant
 - conversion characteristic (inversion, user's non-linear characteristic)
- read the currently measured pressure value of the output current and the percentage output control level
- force an output current with a set value
- calibrate the transmitter in relation to a model pressure

Installation

The transmitter with **P** or **PN** type process connection is not heavy, so can be installed without additional mounting bracket on application. For fitting in any desired position we recommend an universal Apisens mounting bracket for 2" pipe (AL mounting bracket, see page IV/ 5). The version with **C** type process connections can be fitted directly to a 3- or 5- valve manifold. We recommend factory-mounted transmitters with VM type valve manifold (page IV/ 2). A transmitter without a valve manifold can be fitted in any position on a 2" pipe or on a wall using the C-2" mounting bracket (page IV/ 5). When the special process connections are required for the measurement of specific media levels in closed tanks (e.g. in the sugar and chemical industries) the transmitter is fitted with a diaphragm seal. Sets of differential pressure transmitters with diaphragm seals are described in detail in the further part of the catalogue.

Measuring ranges

No.	Nominal measuring range (FSO)	Minimum set range	Rangeability	Overpressure limit/ static pressure limit
1	0...70 bar (0...7 MPa)	7 bar (700 kPa)	10:1	C-type: 250 / 320 / 413 bar (250 bar for PED version) P-type: 40 bar (for range no. 1: 70bar)
2	0...16 bar * (0...1,6 MPa)	1,6 bar (160 kPa)	10:1	
3	0...2,5 bar (0...250 kPa)	0,2 bar (20 kPa)	12,5:1	
4	0...1 bar * (0...100 kPa)	50 mbar (5k Pa)	20:1	
5	0...0,25 bar * (0...25 kPa)	10 mbar (1k Pa)	25:1	
6	-0,5...0,5 bar * (-50...50 kPa)	0,1 bar (10 kPa)	10:1	
7	-100...100 mbar * (-10...10 kPa)	10 mbar (1 kPa)	20:1	
8	-5...70 mbar * (-0,5...7 kPa)	4 mbar (0,4 kPa)	18:1	
9	-25...25 mbar * (-2,5...2,5 kPa)	2 mbar (0,2 kPa)	25:1	
10	-7...7 mbar ** (-700...700 Pa)	1 mbar (0,1 kPa)	14:1	C-type: 200 bar (10 bar for PED version); P-type: 40 bar 20 bar

* available also in HS version
** available only in HS version

Technical data

Metrological parameters

Accuracy $\leq \pm 0,075\%$ of the calibrated range
($\leq \pm 0,1\%$ for range no. 10)
Special version: $\leq \pm 0,05\%$ of the calibrated range

Long term stability \leq accuracy for 3 years
(for the nominal measuring range) $\text{or } \leq 2 \times$ accuracy for 5 years
HS version: \leq accuracy for 6 years
 $\text{or } \leq 2 \times$ accuracy for 10 years

Thermal error $< \pm 0,05\%$ (FSO) / 10°C for ranges no. 1 - 9
 $< \pm 0,08\%$ (FSO) / 10°C for ranges no. 10
max. $\pm 0,25\%$ (FSO) in the whole compensation range
spec. version for ranges no 1-9:

$\leq \pm 0,03\%$ (FSO) / 10°C
max. $\pm 0,1\%$ (FSO) in the whole compensation range

Thermal compensation range -25...80°C

Zero shift error for static pressure

0,01% (FSO) / 10 bar for ranges no. 3, 4, 5, 6, 7, 9
0,03% (FSO) / 10 bar for range no. 8
0,06% (FSO) / 10 bar for ranges no. 1, 2
0,01% (FSO) / 10 bar for ranges no. 2, 8 in HS version
0,02% (FSO) / 10 bar for range no. 10

Zeroing the transmitter in conditions of static pressure can eliminate this error.

Response time 16...480ms (programmable)
Exd version: 150ms

Additional electronic damping 0...60 s

Error due to supply voltage changes 0,002% (FSO) / V

Electrical parameters

Power supply:
10...55 VDC / Exia: 10,5...30 VDC / Exd: 10,5...45 VDC
SIL2: 15...45 VDC / SIL2 Exia: 16...28 VDC

Output signal 4...20 mA + HART

Load resistance (for standard version) $R[\Omega] \leq \frac{U_{\text{sup}}[V] - 10V}{0,0225A}$

Resistance required for communication min. 240 Ω

Materials

Wetted parts SS316L, Hastelloy C276

Diaphragms SS316L, Hastelloy C 276, Au

Casing Aluminium

Option: SS316

Material of window: polycarbonate glass, hardened glass

Operating conditions

Operating temperature range (ambient temp.)	-25...85°C
special version	-40...85°C
Exia version	-25...80°C
Exd version	-25...75°C

Medium temperature range	-25...120°C
over 120°C – measurement with use an impulse line or diaphragm seals	
up to 100°C - PED version	
up to 100°C - version for 413bar static pressure	
up to 80°C - version for 700bar static pressure	

CAUTION: the medium must not be allowed to freeze in the impulse line or close to the process connection of the transmitter

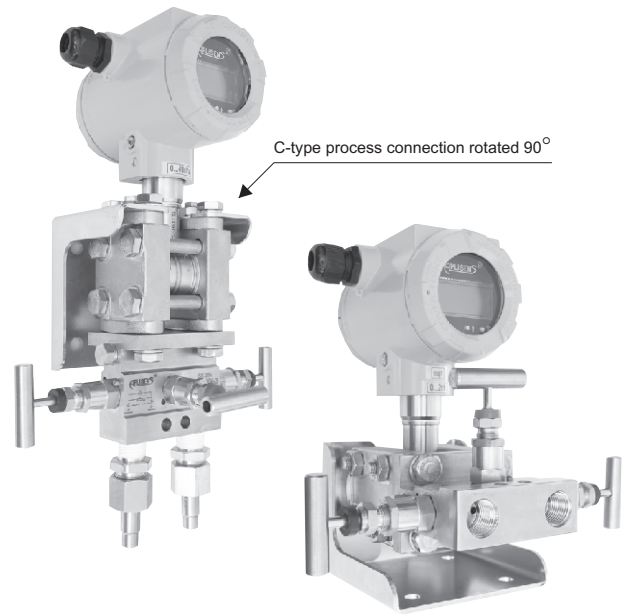

Accuracy depending on the set range

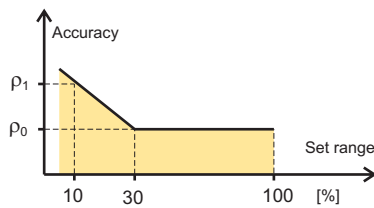

p_0 – error for range 30...100% FSO
 p_1 – error for range 10% FSO
 $p_1 = 2 \times p_0$
 Numerical error values are given in the technical data under metrological parameters

Ordering procedure

Model	Code	Description
HDPM-10		Smart differential pressure transmitter
Casing, output signal	/ALW.....	Aluminum housing, IP66 with display, output 4-20mA + Hart
	/ALW/SS.....	Stainless steel housing, IP66, with display, output 4-20mA + Hart
II 1/2G Ex ia IIC T4/T5 Ga/Gb more than one option is available	/Exia.....	II 1/2G Ex ia IIC T4/T5 Ga/Gb IECEEx Ex ia IIC T4/T5 Ga/Gb
	/Exia (Da).....	II 1/2G Ex ia IIC T4/T5 Ga/Gb II 1D Ex ia IIIC T105°C Da I M1 Ex ia I Ma (version with SS housing) Ex ia IIC T4/T5 Ga/Gb IECEEx Ex ia IIIC T105°C Da Ex ia I Ma (version with SS housing)
	/Exd.....	II 1/2G Ex ia/db IIC T6/T5 Ga/Gb II 1/2D Ex ia/tb IIIC T85°C/T100°C Da/Db I M2 Exd ia I Mb (version with SS housing) Ex ia/db IIC T6/T5 Ga/Gb IECEEx Ex ia/tb IIIC T85°C/T100°C Da/Db Ex db ia I Mb (version with SS housing)
	/Exd (2G).....	II 2G Ex ia/db IIC T6/T5 Gb II 2D Ex ia/tb IIIC T85°C/T100°C Db IECEEx Ex ia/db IIC T6/T5 Gb Ex ia/tb IIIC T85°C/T100°C Db
	/SA.....	Surge arrester for Exia version
	/Safety.....	SIL2 - Functional Safety certificate according to PN-EN 61508-1:2010; PN-EN 61508-2:2010; PN-EN 61508-3:2010; PN-EN 61511-1:2007; PN-EN 62061:2008+A1
	/PED.....	European Pressure Equipment Directive N° 97/23/EC, category IV
	/HS.....	Ultra stable version (only ranges no. 2, 4+10)
	/0,05%	Accuracy ≤ ±0,05%
	/MR.....	Marine certificate – DNV, BV
	/Tlen.....	For oxygen service (sensor filled with Fluorolube fluid)
	/320 bar.....	Static pressure 320 bar, only for C process connection, not available in PED version
	/413 bar.....	Static pressure 413 bar, only for C process connection, not available in PED version
	/700 bar.....	Static pressure 700 bar, only for C process connection, not available in PED version
/IP67.....	Protection class IP67	
/NACE.....	NACE MR-01-75 certificate (process connections: C)	
Nominal measuring ranges	/0+70 bar.....	Range: 0+70 bar (0+7000 kPa) Min. set range: 7 bar (700 kPa)
	/0+16 bar.....	0+16 bar (0+1600 kPa) 1,6 bar (160 kPa)
	/0+2,5 bar.....	0+2,5 bar (0+250 kPa) 0,2 bar (20 kPa)
	/0+1 bar.....	0+1 bar (0+100 kPa) 50 mbar (5 kPa)
	/0+0,25 bar.....	0+0,25 bar (0+25 kPa) 10 mbar (1 kPa)
	/-0,5+0,5 bar.....	-0,5+0,5 bar (50+50 kPa) 0,1 bar (10 kPa)
	/-0,1+0,1 bar.....	-0,1+0,1 bar (-10+10 kPa) 10 mbar (1 kPa)
	/-5+70 mbar.....	-5+70 mbar (0,5+7 kPa) 4 mbar (0,4 kPa)
	/-25+25 mbar.....	-25+25 mbar (-2,5+2,5 kPa) 2 mbar (0,2 kPa)
/-7+7 mbar.....	-7+7 mbar (-0,7+0,7 kPa) 1 mbar (0,1 kPa)	
Measuring set range	/...+... [required units]	Calibrated range in relation to 4mA and 20mA output
Process connections	/C.....	Thread 1/4NPT F on the cover flanges cover flanges material SS316. Allows mounting with a valve manifold. Process connection of cover flange: M10 (option /C(7/16) - 7/16"UNF acc. to IEC 61518)
	/CR.....	C-type process connection rotated 90°
	/P.....	Thread M20x1,5 (male)
	/PN.....	Thread 1/4"NPT (female)
	/code of diaphragm seal.....	Diaphragm seal (see chapter of diaphragm seals) mounted on Hi side of transmitter, Lo side 1/4NPT Female
Material of diaphragms (refers only to C, CR, P, PN process connection)	(without marking).....	Diaphragms material SS316L
	/(H).....	Diaphragms material Hastelloy C276 (all wetted parts in Hastelloy C276 on request)
	/(Au).....	Gold plated diaphragms (not available for transmitters in HS version)
Gasket (refers only to C, CR process connection)	(without marking).....	FPM Viton
	/NBR.....	NBR
	/PTFE.....	PTFE
Electrical connection	(without marking)	Packing gland M20x1,5
	/US.....	Thread 1/2"NPT Female
Accessories	/C-2".....	Mounting bracket for 2" pipe (to C process conn.), mat. zincd steel
	/C-2"(SS).....	Mounting bracket for 2" pipe (to C process conn.), mat. Stainless Steel
	/C-2"B.....	Mounting bracket for 2" pipe (to C(7/16) process conn.), mat. zincd steel
	/C-2"B(SS).....	Mounting bracket for 2" pipe (to C(7/16) process conn.), mat. Stainless Steel
	/FI25.....	Mounting bracket for 1" pipe (to P process conn.), mat. Stainless Steel
	/RedSpaw P.....	Connector to weld impulse pipes dia. 12 and 14 mm, material 15HM(SO) or SS316(S). Only process connection P type
	/RedSpaw C.....	Connector to weld impulse pipes dia. 12 and 14 mm, material 15HM. Only process connection C type.
	/Red d/P 1/2".....	Adapter for differential pressure transmitters with C type process connection, output thread 1/2NPT F. Material SS316L
/ST.....	Stainless Steel plate fixed to the housing	
/MT.....	Stainless Steel Tag plate mounted on wire	
Other specification	/.....	Description of required parameters (e.g. IP66/67)