

BSP Inline Test Point Tee Adaptors

BSP Parallel male x swivel female (60° cone sealing) test point adaptor c/w I 620 Minimesse™ test point fitted.

In line SNA Minimesse® pressure test point adaptors are a simple and easy method of adding test points into a system.

Suitable for OEM build or retro-fitting to existing systems, SNA fit between hose joints or manifold and hose.

Special configurations are available for OEM applications. Call for details.

Also available in JIC, ORFS & Metric formats.



FEATURES:

- Test under pressure using Hydrotechnik leak free minimesse connections up to 630 bar.
- Connect & disconnect under full system pressure.
- In-line test point tees offer excellent system access versatility.

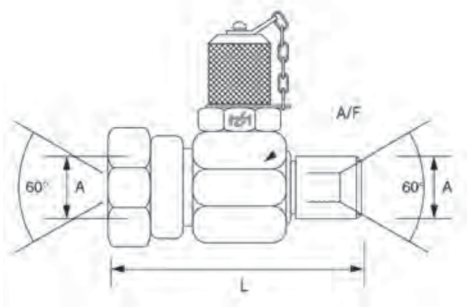

Now available in stainless steel

BSP Format

A	L(mm)	A/F(mm)	Part number	Part number
1/4"	48	25.4	SNA01	SNA01-SS
3/8"	54	25.4	SNA02	SNA02-SS
1/2"	58	27	SNA03	SNA03-SS
3/4"	64	27	SNA04	SNA04-SS
5/8"	63	30	SNA05	on request
1"	74	41	SNA06	SNA06-SS
1 1/4"	74	50	SNA07	on request
1 1/2"	82	55	SNA08	on request

Also available with I215 & I615 test points fitted e.g for I215 series test point fitted to SNA01 - order as SNA01-I215.