

# Mobile Hydraulic Test Equipment Installation and Maintenance Instructions



## I. SPECIFICATIONS

**Temperature Range:** -20 to +116 °C

See Appendix for Pressure vs. Temperature correlation information

**Pressure Rating:** (3:1 safety factor)

½" Sizes; 414 bar maximum

¾" thru 1-½" Sizes; 345 bar maximum

**Pressure Drop:** See Appendix for specific meter information

**Accuracy:** ±2% of full scale

**Repeatability:** ±1%

**Threads:** ISO1179 (BSPP), NPT and SAE available upon request

**Test Kit Pressure Gauge - Glycerin Dampened:**

0-400 bar (0-6,000 psi)

**Test Kit Load Valve:** Pressure compensated, balanced, 414 bar

**Flow Meter Materials of Construction:**

**Body;** T303 Stainless steel

**Piston & Cone;** 2024-T351 Aluminum, anodized

**Spider Plate;** T316 Stainless steel

**Spring;** T302 Stainless steel

**Fasteners;** T303 Stainless steel

**Pressure Seals;** Viton®

**Guard;** Polycarbonate

**Retaining Ring;** SAE 1070/1090 Carbon steel

**Retaining Spring;** SAE 1070/1090 Carbon steel

**Indicator & Internal Magnet;** PPS / Ceramic

**Guard / Bumper;** Buna N

**Scale Support;** 6063-T6 Aluminum

**End Caps;** Nylon ST

# Mobile Hydraulic Test Equipment Installation & Maintenance Instructions

## Installing the Test Kit Flow Meter

1. Mount the VA High Pressure Test Kit Flow Meter so fluid is traveling in the direction of the flow arrow. See **Figure 1**.
2. Install the test kit at any location in the hydraulic circuit that is suitable for viewing. To connect the test kit into the piping system, place an open-ended wrench onto the test kit valve on the inlet side or on the test kit wrench flat on the outlet side adjacent to the pipe connection being installed. **DO NOT** wrench on the opposite end of the test kit or leakage may result. See **Figure 2**.

Or, use quick disconnect couplings for easy connections and to keep the test kit sealed and clean when not in use. Diagrams illustrating Typical Test Placements for the test kits are located in the Test Procedures section beginning on page 3.

3. After installation, rotate meter by hand to view flow scale. See **Figure 3**.

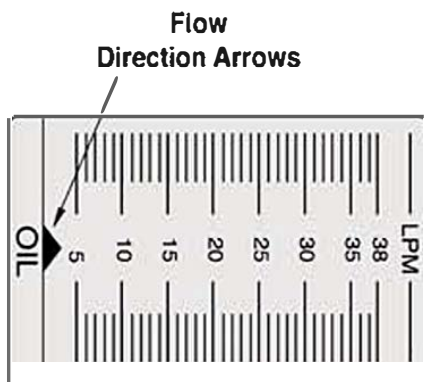

**Figure 1. Flow Direction Arrows**

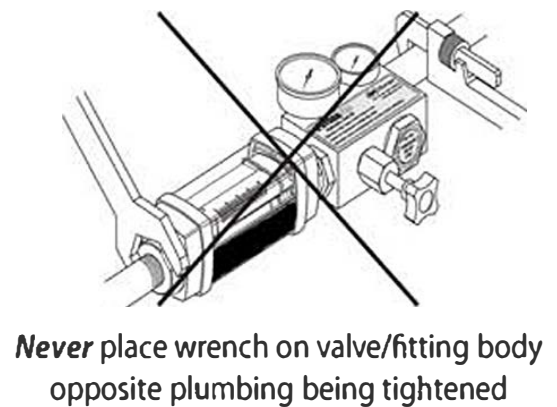
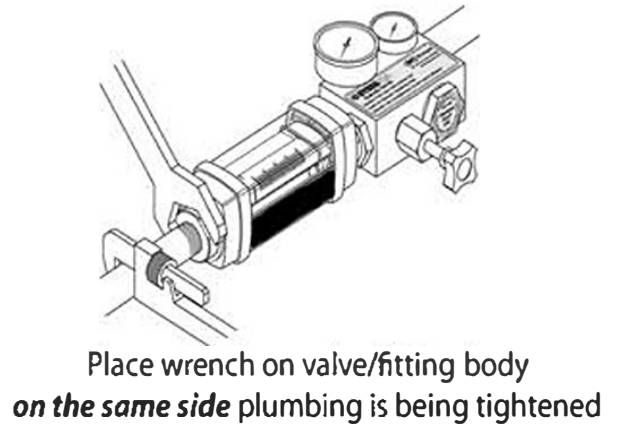

**Figure 2. Installing Test Kit**

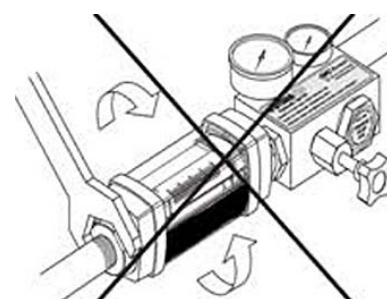
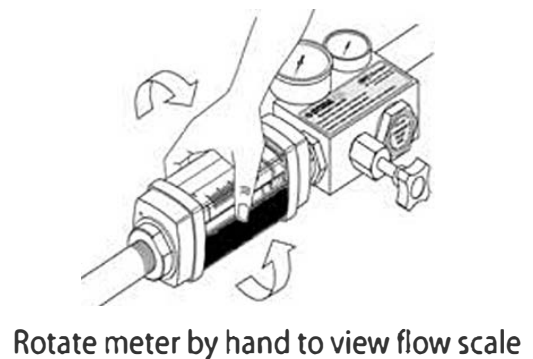

**Figure 3. Rotating Test Kit**

**Figure 3. Rotating Test Kit**

# Mobile Hydraulic Test Equipment Installation & Maintenance Instructions

## II. OPERATION

### General Information

*NOTE: Refer to the Appendix for application information and fluid charts.*

### Test Kit Information

## ALWAYS START WITH THE LOADING VALVE OPEN

### WARNING

All Test Kits are shipped with the loading valve in the closed position. The loading valve must be opened fully before initiating flow and testing of the hydraulic circuit. Turn the loading valve handle counterclockwise to the fully open position. Failure to open the loading valve fully can result in injury to personnel and/or damage to the equipment.

## III. TEST PROCEDURES FOR TEST KIT FLOW METERS

### CAUTION

The information in this manual is for general application only. Any information furnished by the manufacturer of the machine's hydraulic components should be followed. Specific systems may require specific test procedures.

### General Information

The VA High Pressure Test Kits are designed to measure flow and pressure. Power measurements are derived from the product of flow and pressure. When using a Test Kit, power can be calculated using the following formulas:

$$\text{H.P.} = \frac{\text{GPM} \times \text{PSI}}{1714} \quad \text{H.P.} = \frac{\text{liters/min} \times \text{bar}}{447.4}$$
$$\text{kW} = \frac{\text{liters/min} \times \text{bar}}{600}$$

### Standard Test Conditions

1. Install the Test Kit as described in one of the following test procedures:
  - a. Pump Test
  - b. "Tee" Test
  - c. Relief Valves in Separate Housings
  - d. Relief Valves
2. Open the loading valve fully by turning the handle counterclockwise.
3. Start the pump and adjust it to rated speed.
4. Open the Test Kit loading valve fully and proceed with the required test procedure.
5. The Test Kit will indicate flow and pressure.

### Pump Test (See Figure 4 on page 4)

A tee must be installed between the pump discharge port and the return line to the tank. Be sure the fluid path is only through the pump, the hydraulic test unit, and back to the tank.

1. Plug the line to the control valve.
2. Open the Test Kit loading valve fully to read maximum pump flow at zero pressure.

## Mobile Hydraulic Test Equipment Installation & Maintenance Instructions

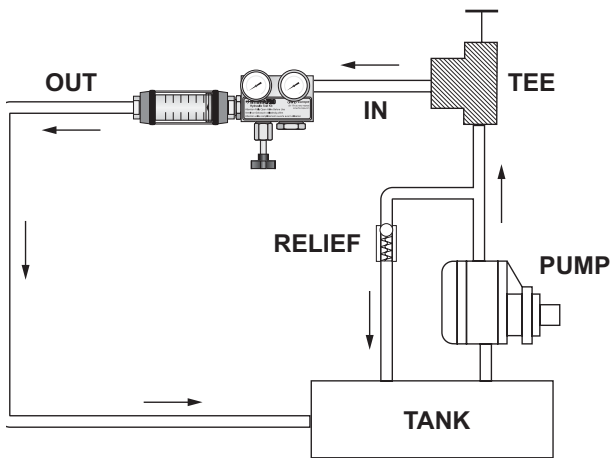

**Figure 4. Pump Test**

3. Close the loading valve to increase pressure from zero pressure to rated or maximum pump pressure to determine pump condition.
4. The pump flow at rated pressure can now be checked against the pump manufacturer's specifications. A decrease in flow from zero pressure to maximum pressure indicates the pump condition. A pump that delivers a constant low flow at zero pressure and at maximum pressure suggests suction problems.

### "Tee" Test (See Figure 5)

A tee must be installed between the pump and control valve and connected to the inlet of the Test Kit. The outlet port of the Test Kit is connected to the tank. Pumps and relief valves can be isolated from the system and checked with the "Tee" Test.

1. Pump Test
  - a. Plug the line to the control valve.

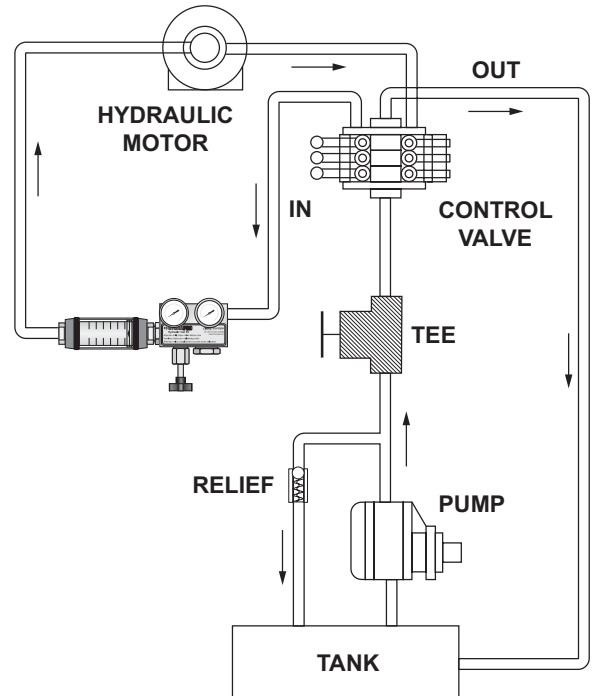

**Figure 5. "Tee" Test**

- b. Open the Test Kit loading valve fully to read maximum pump flow at zero pressure.
- c. Close the loading valve to increase pressure from zero pressure to rated or maximum pump pressure to determine pump condition.
- d. The pump flow at rated pressure can now be checked against the pump manufacturer's specifications. A decrease in flow from zero pressure to maximum pressure indicates the pump condition. A pump that delivers a constant low flow at zero pressure and at maximum pressure suggests suction problems.

# Mobile Hydraulic Test Equipment Installation & Maintenance Instructions

---

## 2. Relief Valve Test

- a. Put a control valve into a power output mode with the output flow blocked, such as a cylinder at the end of its stroke.
- b. Close the Test Kit loading valve while viewing the pressure. Pressure will increase until the relief valve opens. Record the pressure at this point. Repeat to check the relief valve adjustment.

## Relief Valve in Separate Housing

1. Install the Test Kit in a "Tee" Test configuration to the line connecting the pump and relief valve. Plug any extra outlets.
2. Close the Test Kit loading valve and watch the pressure and flow.
  - a. Reconnect the control valve to the tee. Put a control valve into a power output mode with the output flow blocked, such as a cylinder at the end of its stroke.
  - b. Close the Test Kit loading valve while watching the pressure. Pressure will increase until the relief valve opens. Record the pressure at this point. Repeat to check the relief valve adjustment.

## Relief Valves

Often relief valves will start to open before they reach their full pressure flow settings. This can be noted by comparing the pressure and flow rate readings made in Step 3 under "Tee" Test. Any great decrease in flow rate from tests made in Step 3 under "Tee" Test indicates a faulty relief valve.

## IV. MAINTENANCE



### WARNING

Before attempting to remove the flow meter from the line, check the system to confirm that line pressure has been reduced to zero PSI. Failure to follow these instructions could result in serious personal injury or death and/or damage to the equipment.

1. Remove the flow meter from the line. Remove excess piping from meter.

*NOTE: It is not necessary to remove the transparent dust guard from the meter to remove the meter from the line. If you choose to remove the dust guard assembly, refer to Removal of Dust Guard section on page 6.*

2. Thoroughly wipe off the entire flow meter surface using mild detergent or isopropyl alcohol.



### CAUTION

Do not use aromatic hydrocarbons, halogenated hydrocarbons, ketones or ester based fluids on polycarbonate lens. Failure to follow these instructions could result in damage to the meter.

---

## Mobile Hydraulic Test Equipment Installation & Maintenance Instructions

---

3. Remove the inlet cap from the flow meter, noting the sequence of disassembly for later reference (during reassembly).
4. The internal parts are secured with a retaining ring. Remove the retaining ring and the internal wetted parts from the flow meter.

*NOTE: If internal parts do not slide freely from flow meter, use a wooden dowel inserted into the outlet port of the meter to push parts out.*

5. Place all parts on a clean work surface. Clean and inspect all parts. Replace any that appear worn or damaged. Check inlet port O-ring for damage and replace if required.



### CAUTION

Field replacement of the spring, metering cone and/or piston/magnet assembly may result in changes to the calibration of the flow meter.

6. Reassemble spring, then piston/magnet assembly and retaining ring into flow meter.
7. Install metering cone/spider plate assembly, retaining spring, and secure with inlet cap.
8. Reinstall meter to the line.

### Removal of Dust Guard

To remove the dust guard for cleaning or replacement, simply loosen the end fitting located at the bottom of the meter and slide the end cap, dust bumper, and the dust guard off the bottom of the meter, taking care to avoid damaging the O-ring seal between the end cap and the dust gland.

### Quick Re-Coupling

This piston-type variable area flow meter is inherently less sensitive to shock and vibration than other variable area designs. The unique magnetic coupling also eliminates the need for mechanical linkages that can wear or loosen over the functional life of the meter.

However, on occasion, a pressure spike or extreme flow surge can cause the piston to move at such rapid speed that it disconnects the piston magnet and the external indicator ring. If this occurs, use one of these procedures to re-couple the magnet and the external indicator ring:

- If the system permits, simply change flow rate from “no flow” to “full flow” allowing the moving piston to magnetically re-couple to the indicator ring.
- For rigorous cyclical applications where de-coupling may occur frequently, consult the technical services staff for further recommendations.

### Test Kit Maintenance

#### Load Valve

If the valve fails to load the system, remove the valve body and check for foreign material, worn parts or seals.

#### Flow

The absence of any flow reading may indicate a seized piston assembly. Remove any material that may be preventing the piston to slide.

If the Test Kit still fails to indicate flow, it is recommended to return the Test Kit to the factory.

---

# Mobile Hydraulic Test Equipment Installation & Maintenance Instructions

## V. APPENDIX

### Application Information

#### Viscosity Effect (SUS/cSt)

The design utilizes a precision machined, sharp-edged orifice and biasing calibration spring that assures operating stability and accuracy over the wide viscosity range common to many fluids. Generally, high flow models of each meter size provide good accuracy over a viscosity range of 40 to 500 SUS (4.2 to 109 cSt).

#### Density Effect (specific gravity)

Any fluid density change from stated standards has a proportional effect on meter accuracy. Special scales can be supplied if actual specific gravity decreases accuracy beyond application limits. Corrections for more or less dense fluids can be made to standard scales using the following correction factors:

$$\sqrt{\frac{0.876}{\text{Specific Gravity}}} \quad \text{for petroleum-based meters}$$

### Fluid Selection Chart

Fluid	Specific Gravity	Correction Factor of Standard Oil Scale	Material		External Pressure Seals		Dust Guard
			Load Valve HT Aluminum	Flow Meter T303SS Body Alum Internals	Viton®	EPR	
Acetic Acid (Air-Free)	1.06	0.909	C	C	R	R	C
Acetone	0.79	1.053	R	R	N	R	N
Alcohol Butyl (Butanol)	0.83	1.027	C	C	C	R	R
Alcohol Ethyl (Ethanol)	0.83	1.027	C	C	C	R	R
Ammonia	0.89	0.992	R	R	N	R	N
Benzine	0.69	1.127	C	C	R	N	N
Carbon Disulphide	1.26	0.834	R	R	R	N	N
Castor Oil	0.97	0.950	C	C	R	N	C
Cotton Seed Oil	0.93	0.970	C	C	R	N	R
Ethylene Glycol 50/50	1.12	0.884	R	R	R	R	R
Freon II	1.46	0.774	R	R	R	N	R
Gasoline	0.70	1.119	R	R	R	N	C
Glycerin	1.26	0.834	R	R	R	R	R
Kerosene	0.82	1.033	R	R	R	N	R
Liquid Propane (LPG)	0.51	1.310	R	R	R	N	N
Mineral Oil	0.92	0.976	R	R	R	N	R
Naptha	0.76	1.074	R	R	R	N	C
Perchloroethylene	1.62	0.735	C	C	R	N	N
Petroleum Oil	0.876	1.000	R	R	R	N	R
Phosphate Ester	1.18	0.862	R	R	N	R	N
Phosphate Ester Base	1.26	0.833	R	R	N	R	N
Phosphoric Acid (Acid Free)	1.78	0.701	N	N	R	N	R
Sea Water	1.03	0.922	N	N	N	R	R
Synthetic Petroleum Base	1.00	0.936	R	R	R	N	R
Water	1.00	0.936	N	N	N	R	R
Water Glycol 50/50	1.07	0.905	R	R	R	N	R
Water-in-oil	0.93	0.970	R	R	N	R	R

### Pressure vs. Temperature Chart

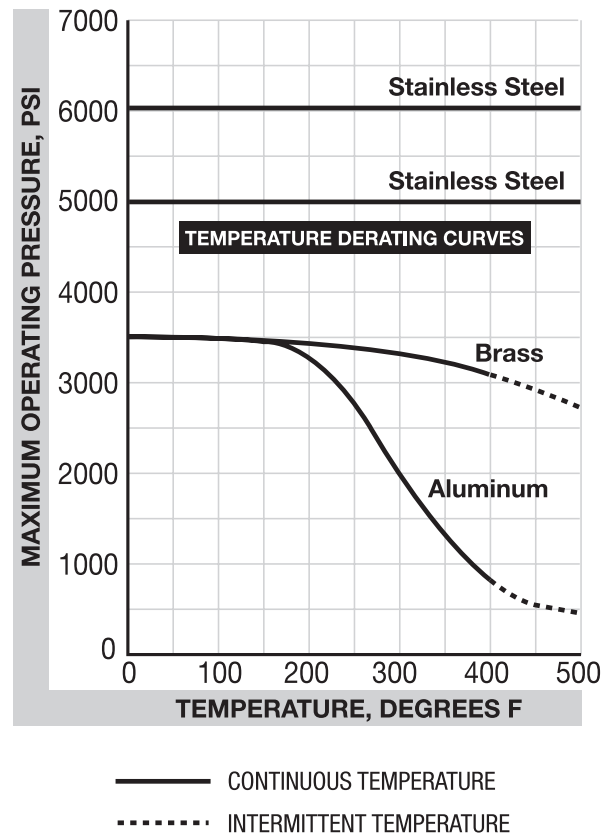

# Mobile Hydraulic Test Equipment Installation & Maintenance Instructions

## Flow vs. Pressure Drop

### Petroleum Fluids Flow Meter

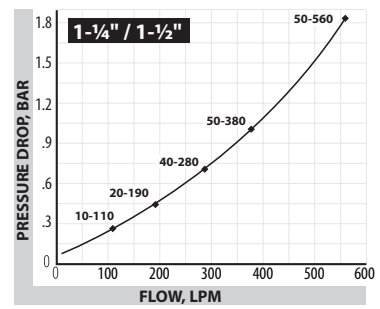
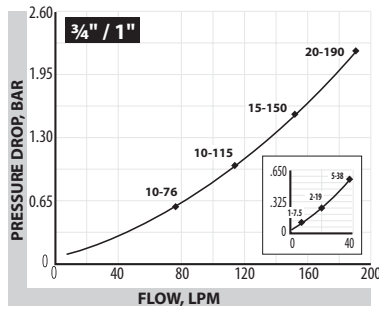
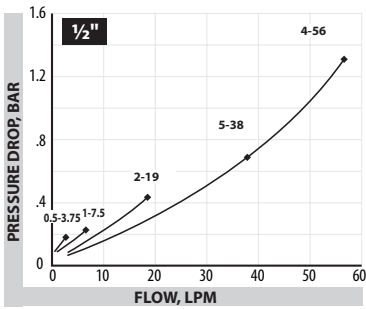

### Petroleum Fluids Test Kits

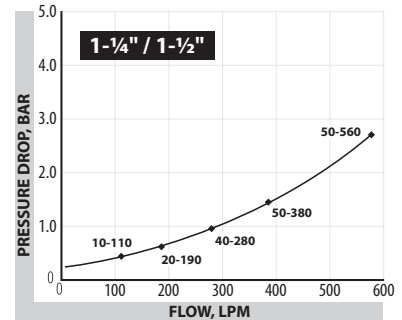
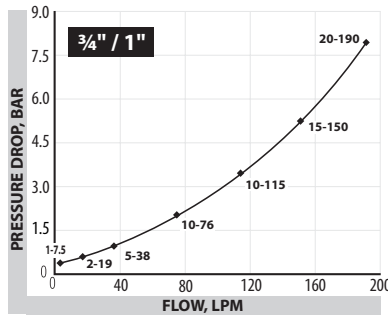
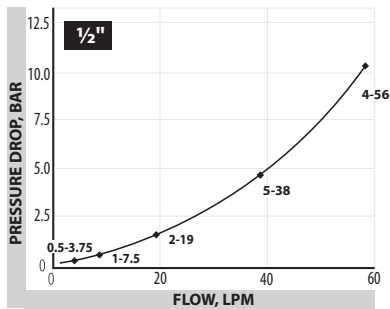

Materials & specifications are subject to change without notice.

VITON is a registered trademark of DuPont Dow Elastomers.  
UL is a registered trademark of Underwriters Laboratories.