

**This range of flowmeters will provide you with a highly accurate and economical way of measuring liquids over the range of 1 to 2250 litres/min.**

### Robust stainless steel construction ✓

Corrosion resistant  
 Very low maintenance and down time  
 Withstands high temperature and pressure

### Highly accurate measurement of flow ✓

Well proven  
 Improve product quality  
 Reduce waste and costs

### High quality manufacture ✓

ISO 9001 certified company  
 Approvals for use in hazardous areas  
 Individual calibration certificates

### Low pressure drop ✓

### Bi-directional flow capability ✓



#### Application

This range of flowmeters is used for liquids such as water, light oils, solvents and low viscosity chemicals. You can use them for batching, flow rate monitoring, controlling, blending and filling. The flowmeter is highly accurate and often used for testing the performance of pumps, engines, valves and other flowmeters.

In hazardous areas you can use the flowmeters with the IS pick-off coil approved to ATEX II 1 G EEx ia IIC T5. The signal can be used in the IS area or transmitted to the safe area using the intrinsically safe P5 preamplifier and suitable barriers.

#### Instrumentation

The signal can be used for a local display, remote display or converted for transmission to a separate control system. We have a range of instruments to suit all your requirements.

#### Principle of Operation

When liquid flows and the rotor turns, the sensor detects the movement of the blade tips and generates pulses. The frequency of the pulses is proportional to the flowrate.

#### Construction

The stainless steel construction is durable and gives excellent corrosion resistance. The rotor is machined from solid making it virtually indestructible. The sleeve bearings provide you with highly reliable performance over long periods.

#### Calibration

All RN3 turbine flowmeters are individually calibrated with water and are traceable to national standards.

We provide you with a test certificate for each meter showing the number of pulses per litre, which is used to set the instrumentation.

#### Installation

The flowmeter is installed directly into the pipeline. To reduce turbulence and get the best results from your flowmeter we recommend that you install it in a straight section of pipe with at least 10 pipe diameters upstream and 5 pipe diameters downstream.

Control valves should be installed downstream of the flowmeter.

To prevent foreign particles blocking your line we recommend you install a filter before the flowmeter. Preamplifiers are only needed if you have very long transmission distances or an electrically noisy environment close to pumps, motors, generators, switchgear or heavy current carrying cables. Intrinsically safe systems always require an IS pick-off coil. The IS P5 preamplifier is required for transmission to a safe area through barriers.

### Specification

**Linearity:** Better than +/- 0.5% of reading  
**Repeatability:** +/-0.1% of reading  
**Pressure drop:** 0.5 bar at maximum flow  
**Maximum overrange:** Up to 120% of the maximum flow rate for short durations  
**Maximum working pressure:** 35 bar (special connections available up to 350 bar)  
**Temperature range:** Standard pickoff -30 °C to 110 °C  
 IS pickoff -30 °C to 110 °C  
 High temp -30 °C to 232 °C  
**Body connections:** BSP parallel thread with 60° cone special connections are available for hydraulic applications

### Materials of Construction

**Body:** 316 stainless steel  
**Sleeve bearings:** Standard - carbon graphite filled PTFE (max temp. 180 °C)  
 Optional tungsten carbide (max temp. 300°C)  
**Thrust balls:** Tungsten carbide  
**Rotor:** 431 S/S or ferralium  
**Rotor shaft:** Tungsten carbide  
**Hangers:** 316 stainless steel  
**Circlips:** 316 stainless steel

### Flowrate Ranges

Model No	Flow Range Ltr/min	K factor pulses / litre <sup>#</sup>
RN3/10	1-10	5000
RN3/15	2-20	3800
RN3/20/5	5-50	1080
RN3/20/8	8-80	1080
RN3/25/15	15-150	620
RN3/25	25-250	362
RN3/32	45-450	111
RN3/40	67-670	82
RN3/50	110-1100	59
RN3/65	225-2250	19

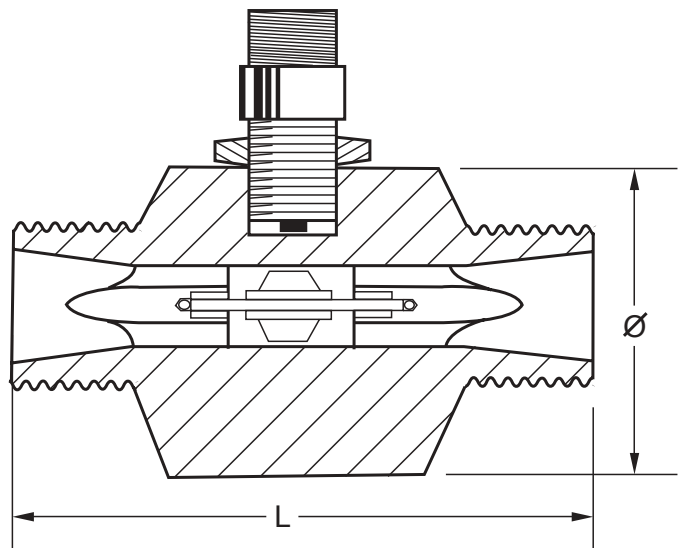

### Dimensions

Model Number	Thread Size BSP	L mm	Dia mm	Weight kg
RN3/10	3/8"	82.6	38.0	0.3
RN3/15	1/2"	82.6	50.0	0.5
RN3/20/5	3/4"	82.6	50.0	0.5
RN3/20/8	3/4"	82.6	50.0	0.5
RN3/25/15	1"	90.5	63.5	1.0
RN3/25	1"	90.5	63.5	0.8
RN3/32	1 1/4"	110.0	75.0	1.6
RN3/40	1 1/2"	116.7	76.2	1.7
RN3/50	2"	154.0	89.0	3.1
RN3/65	3"	170.0	95.0	3.5

# The nominal K factor is based on water at 20°C  
 Each flowmeter is individually calibrated on water and will have a unique K factor.